

## Unit-III

# Oscilloscopes

In many applications it is necessary to investigate the waveforms having very high frequency or the signals which are non repetitive & single event. In some applications, the data is required to be stored & to be used later whenever necessary. Such special functions cannot be achieved using conventional oscilloscopes. The special oscilloscopes are necessary to perform such special functions.

### Multiple Trace oscilloscopes or Multi-input oscilloscopes

oscilloscopes can have multiple input & display facilities. Two inputs is the most common, although four & eight inputs are available for special applications. There are two primary types: Single beam which can be converted into several traces, and dual beam which may also subsequently be converted into a further number of traces.

### Dual trace oscilloscopes

The comparison of two or more voltages is very much necessary in the analysis & study of electronic circuits & systems. This is possible by using more than one oscilloscope but in such a case it is difficult to trigger the sweep of each oscilloscope precisely at the same time. A common & less costly method to solve this problem is to use dual trace oscilloscopes. In this method, the same electron beam

is used to generate two traces which can be deflected from two independent vertical sources. The two methods are used to generate two independent traces which are alternate sweep method & other is chop method.

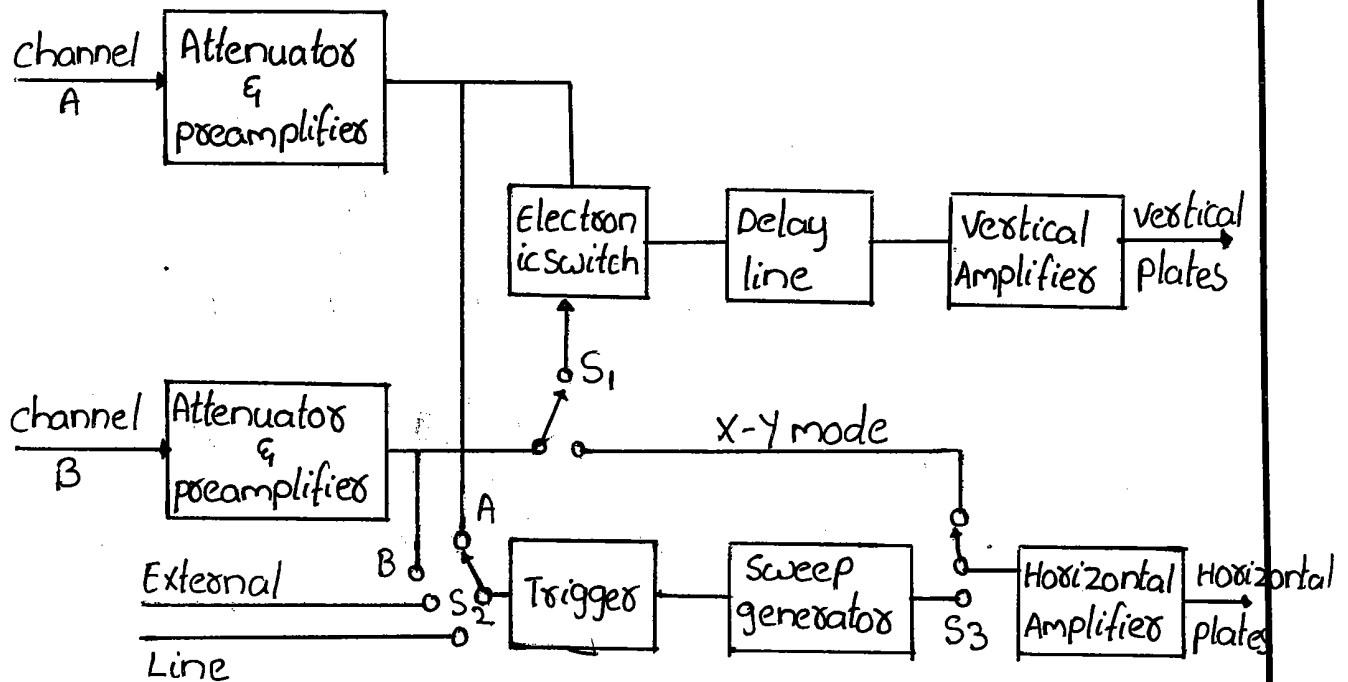

### Block diagram of dual trace oscilloscope

There are two separate vertical input channels A & B. A separate preamplifier & attenuator stage exists for each channel. Hence amplitude of each input can be individually controlled. After preamplification stage both the signals are fed to an electronic switch. The switch has an ability to pass one channel at a time via delay line to the vertical amplifiers. The time base circuit uses a

triggers selector switch  $S_2$  which allows the circuit to be triggered on either A or B channel, on line frequency or on an external signal. The horizontal amplifier is fed from the sweep generator or the B channel via switch  $S_1$  &  $S_3$ . The X-Y mode means, the oscilloscope operates from channel A as the vertical signal & the channel B as the horizontal signal. Thus in this mode very accurate X-Y measurements can be done.

Depending on the selection of front panel controls several modes of operation can be selected such as channel A only, channel B only, channel A & B as separate traces, signals  $A+B$ ,  $A-B$ ,  $B-A$  or  $-(A+B)$  as single trace.

These are two common operating modes for the electronic switch.

### Alternate Mode:

When the display mode selector is in the alternate mode the electronic switch alternately connects the vertical amplifiers to channel A & channel B. Initially each vertical amplifier is adjusted with the help of attenuator & position control such that the two images are positioned separately on the screen. An electronic switch is controlled by using a toggle flipflop. The switching takes place at the start of each new sweep. The switching rate of an electronic switch is synchronized to the sweep rate so that CRT

spot traces channel A signal on one sweep & channel B signal on the next succeeding sweep. Thus two channels are alternately connected to the vertical amplifier. The change over of an electronic switch takes place during the flyback period of the sweep. During the flyback, the electron beam is invisible & the change over is also invisible. Thus the alternate mode displays one vertical channel for a full sweep & the next vertical channel for next sweep.

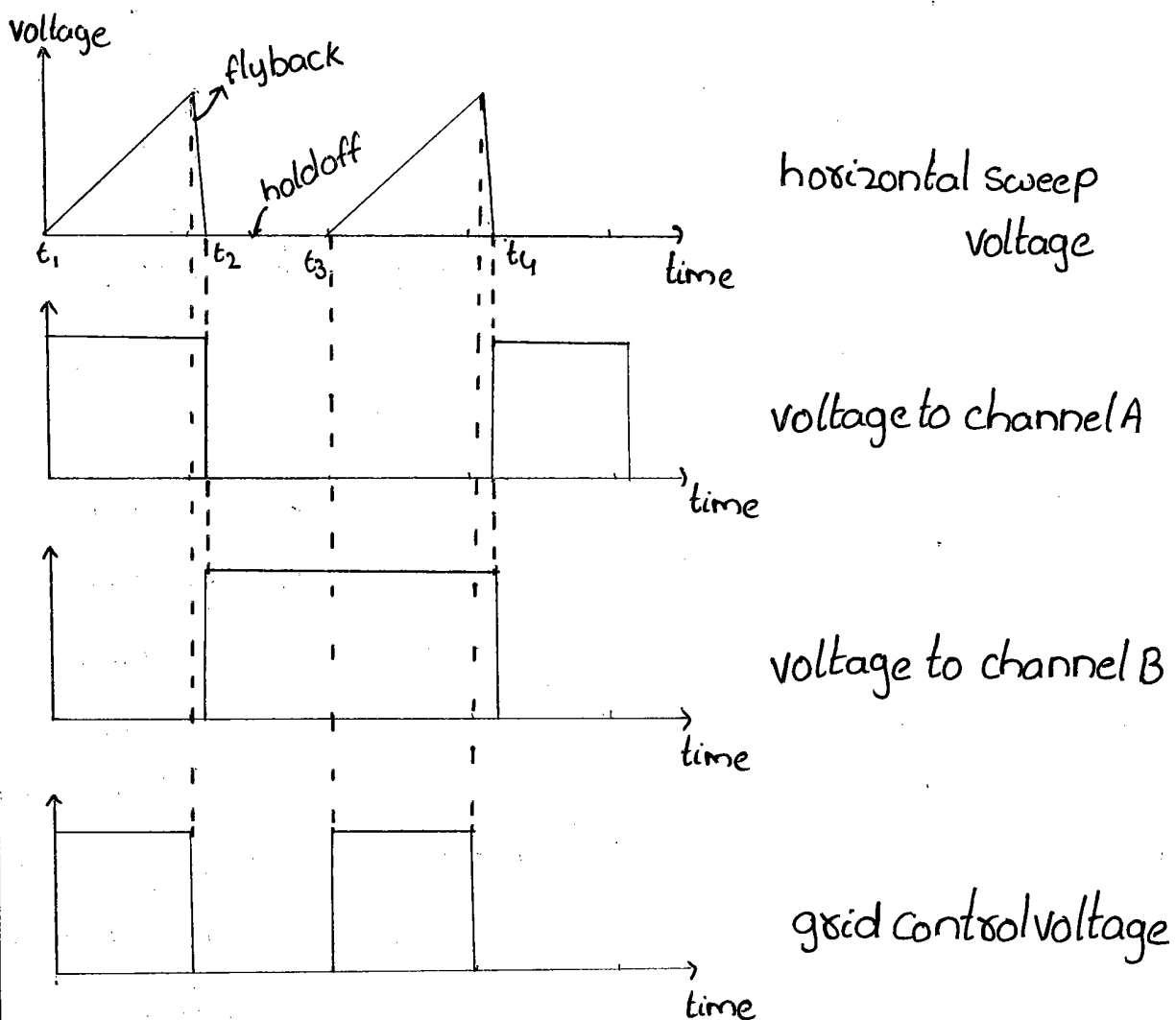

The main limitation of this method is that the display is not the actual representation of two events taking place simultaneously. The signals are displayed as if they were existing at two different times. Similarly, the alternate mode cannot be used for displaying very low frequency signals. [The display is blanked during the flyback period provided the sweep speed is much greater than the decay time of Chop Mode CRT phosphor, the screen will show a stable display of both the waveforms at channel A & B.]

In this method, there is a switching from one vertical channel to other, many times during a single sweep. This switching from one vertical channel to other is at such a rapid rate that the display is created from small segments of the actual waveform.

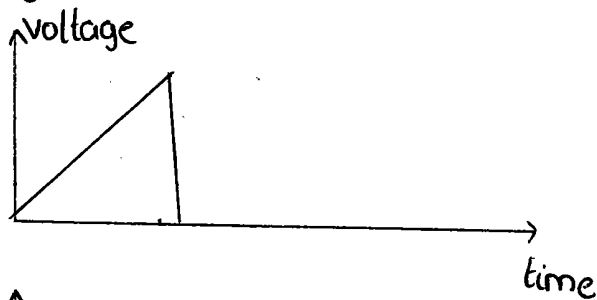

Horizontal sweep voltage

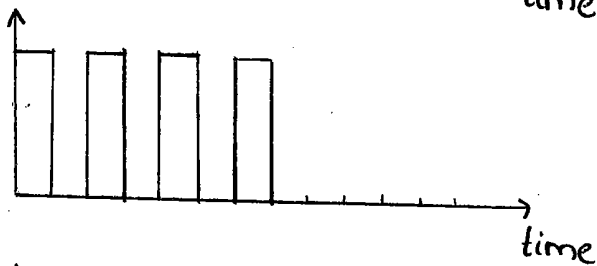

voltage to channel A

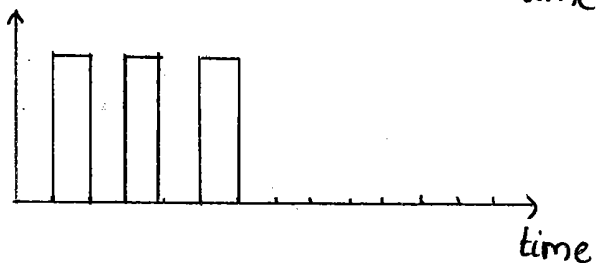

voltage to channel B



The electronic switch is free running oscillator at a rate of 100 to 500 kHz entirely independent of the sweep generator frequency. Thus the switch successively connects the small segments of channel A & B waveforms to the main amplifiers.

If the chopping rate is faster than horizontal sweep rate, then the individual little segments fed to the sweep vertical amplifiers together reconstitute the original A & B waveforms on the CRT screen without any visible interruptions. The little chopped segments merge to appear continuous to the eye.

If chopping rate is much faster than the horizontal sweep rate, the display will show a continuous line for each channel. but if the chopping rate is small, the continuity of the display is lost. In such case, it is better to use alternate mode.

## Sampling Oscilloscope

As the frequency of the input signal to the vertical amplifier increases, the writing speed of the electron beam increases. This reduces the image sensitivity on the screen. For high frequency signals the electron beam is required to accelerate more. Such increase in velocity is possible by increasing the voltage of accelerating anodes but it requires higher deflection potential & puts higher demands on the vertical amplifier.

The solution to such problem is the sampling technique. Using this technique, higher frequency signal is converted to low frequency signal. In this technique; instead of monitoring the input signal continuously, it is sampled at the regular intervals. These samples are presented on the screen in the form of dots. Many thousand of dots may be displayed on the screen. Such samples are merged to reconstruct the input signal. Due to merging of samples, observer receives a continuous signal on the screen. Thus a very high frequency more than 300 MHz performance can be achieved using this technique.

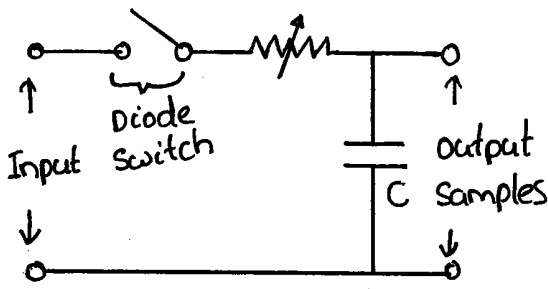

Basic sampling circuit

It consists of a diode switch which is also called sampling gate, a series resistor & a shunt capacitor. When switch is closed, the capacitor charging starts. But

switch is closed for very short duration of time so that sample of the input signal is presented at the output.

The sampling pulse is required to turn on the sampling circuit, i.e. to close the switch for very short duration of time. The input voltage at that instant is available at the sampler output & presented as a dot on the CRT screen. The next sample is taken during a subsequent cycle of the input waveform at a slightly later position. Thus the spot on the screen moves horizontally by a small distance & repositioned to the new value of the input.

In this way, 1000 samples i.e. dots are presented on the screen which together reconstruct the original input signal. The separate time base circuit provides the sampling pulses required by the sampling gate.

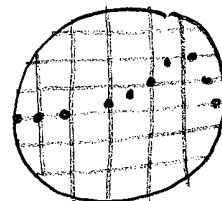
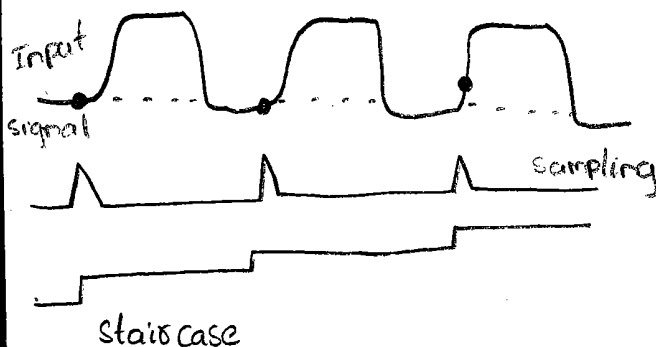



**Sampling Time Base** The time base circuit of the sampling oscilloscope is different than the conventional oscilloscope. The time base of sampling oscilloscope has two functions:

- i. To move the dots across the screen
- ii. To generate the sampling command pulses for the sampling circuit.

It consists of synchronous circuit, which determines, the sampling circuit rate & establishes a reference point in time with respect to the input signal.

The time base generates a triggering pulse which activates the oscillator to generate a ramp voltage. Similarly it gives a stair case waveform. The ramp generation is based on the output of the synchronizing circuit.

Both the ramp as well as staircase waveforms are applied to a voltage comparator. This comparator compares the two voltages & whenever these two voltages are equal, it generates a sampling pulse. This pulse then momentarily bias the diodes of the sampling gate in the forward direction & thus diode switch gets closed for short duration of time. The capacitor charges but for short time. Hence it can charge to

only a small percentage of the input signal value at that instant. This voltage is amplified by the vertical amplifiers & then applied to the vertical deflecting plates. This is nothing but a sample. At the same time the comparator gives a signal to the staircase generator to advance through one step. This is applied to horizontal deflecting plates, thus during each step of the staircase waveform, the spot moves across the screen.

Thus the sampling time base is called a staircase ramp generator in case of a sampling oscilloscope.

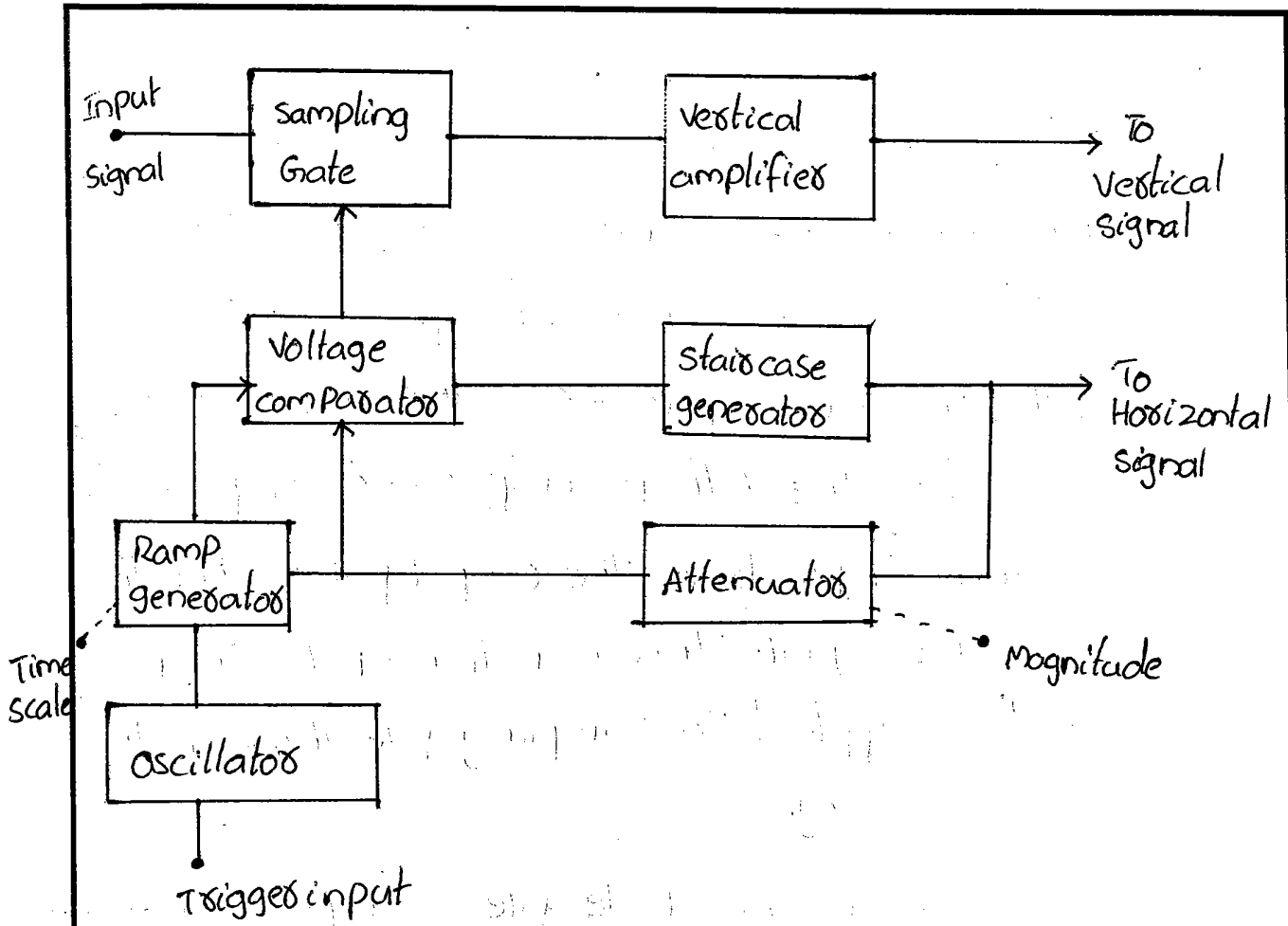

The input signal is applied to the diode sampling gate. At the start of each sampling cycle a trigger input pulse is generated which activates the blocking oscillator. The oscillator output is given to the ramp generator which generates the linear ramp signal.

Since the sampling must be synchronized with the input signal frequency, the signal is delayed in the vertical amplifier.

The staircase generator produces a staircase waveform which is applied to an attenuator. The attenuator controls the magnitude of the staircase signal & then it is applied to a voltage comparator. Another input to the voltage comparator is the output of the ramp generator. The voltage comparator compares the two signals & produces the output pulse when the two voltages are equal. This is nothing but a sampling pulse which is applied to sampling gate through the gate control circuitry.

This pulse opens the diode gate & sample is taken in. This sampled signal is then applied to the vertical amplifier & the vertical deflecting plates.

The output of the staircase generator is also applied to the horizontal deflecting plates. During each step of the staircase the spot moves on the screen. The comparator output advances the staircase output through one step.

After certain number of pulses about thousand or so, the staircase generator resets. The smaller the size of the steps of the staircase generator

larger is the number of samples & higher is resolution of the image.

In sampling oscilloscope, a staircase generator is used as input to horizontal section instead of ramp. The sampling of the waveform is done at the beginning of each step of the staircase waveform. The sampled output is used for the vertical section. When this sampled output is combined with the unblanking pulses, a dot waveform is obtained on the screen.

### Storage oscilloscope

In the conventional CRT the persistence of the phosphor ranges from a few ms to several seconds, so that an event that occurs only once will disappear from the screen after a relatively short period of time. A storage CRT can retain the display much longer, upto several hours after the image was first written on the phosphor. This retention feature can also be useful when displaying the waveform of a very low-frequency signal.

Storage CRTs can be classified as bistable tubes & half tone tubes. The bistable tube will either store or

not store an event & produces only one level of image brightness. The half tone tube can retain an image for varying lengths of time & at different levels of image brightness. Both the bistable & half tone use the phenomenon of secondary emission to build up & store electrostatic charges on the surface of an insulated target.

principle of secondary emission

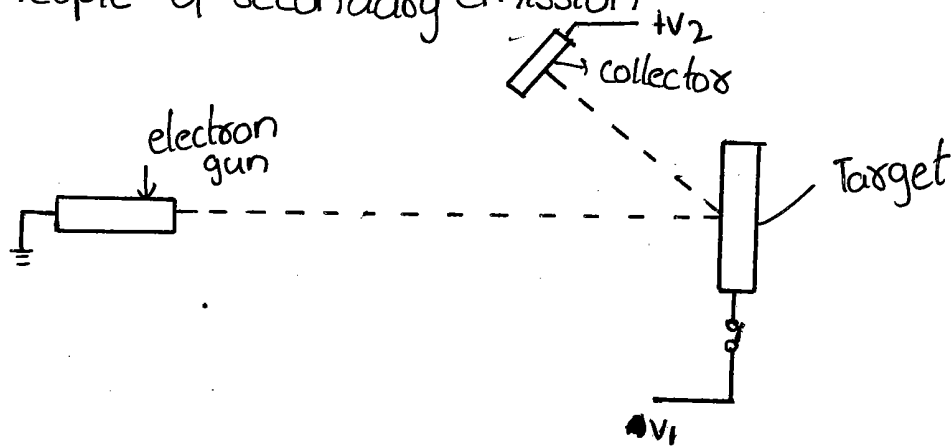

Fig shows a simple electrode arrangement.

When a beam of electrons from the electron gun strikes the target it emits secondary electrons which are gathered by the collector. The collector is at a positive potential of  $V_2$ , the target is at a potential of  $V_1$ , which can be varied, & the electron gun is at ground potential.

If  $I_p$  is the value of the current in the primary electron beam, coming from the electron gun &  $I_s$  is the electron current emitted from the target & collected by the collector, then the ratio  $I_s/I_p$  is called the

Secondary emission ratio. The value of this ratio depends on the primary electron velocity & intensity & on the chemical composition of the target.

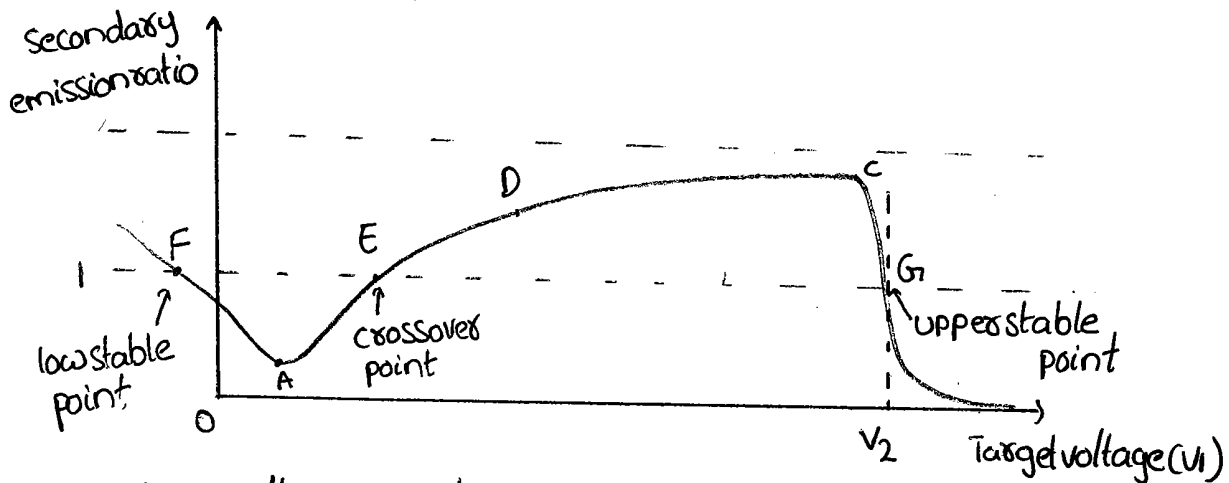

Fig shows the variation of the secondary emission ratio with the target voltage.

When the target voltage is much greater than the collector voltage, all secondary electrons emitted from the target are attracted back to it. Therefore the collector current or secondary current is zero & also secondary emission ratio is zero. The operating point is now well to the right of  $V_2$  in fig.

If the target voltage is slightly negative, as at point F, then all the electrons from the gun are deflected on to collector, before they reach the target therefore although there is no secondary emission the collector current equals the beam current & the

Secondary emission ratio is unity. This point is known as the lower stable point.

As the target voltage increases from this point electrons are attracted away from the collector, but they do not have enough energy to release secondary electrons from the target. Therefore the secondary emission ratio falls to a minimum at A. Beyond the minimum point secondary emission from the target starts to occur, & these electrons are accumulated by the collector, so increasing the secondary emission ratio.

The secondary emission ratio increases through the crossover point E until it reaches a peak at C. Beyond this point secondary electrons emitted from the target are attracted back; in number greater than those which reach the collector, so that the secondary emission ratio decreases sharply. The curve reaches the upper stable point at G, where the primary & secondary currents are equal & then decreases to zero.

The lower & upper stable points represent the erased & written condition of CRT screen & in the absence of a target voltage the target can remain in one of these two stages only. Suppose for instance that the target is in a state to the left of the cross over point E



A switch SW is opened to remove the target supply voltage. Because the secondary emission ratio is less than one, fewer electrons leave the target than arrive at its surface, so the target is driven progressively negative until point F is reached. Now the number of electrons reaching the target equals to the number which are emitted from it. This represents a stable erased state.

If the target was to right of the crossover point when switch SW is opened, then since the secondary emission ratio is greater than one, more electrons leave the target than arrive at its surface. The target is therefore driven positive until it reaches the upper stable point G, which represents the written condition of the screen. The target will stay at the upper or lower stable point so long as the electron gun is on.



multiple target & flood gun arrangement

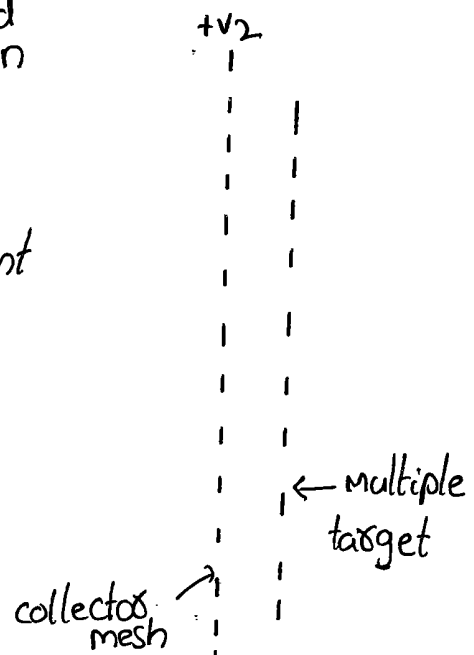
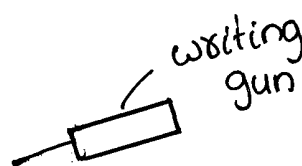
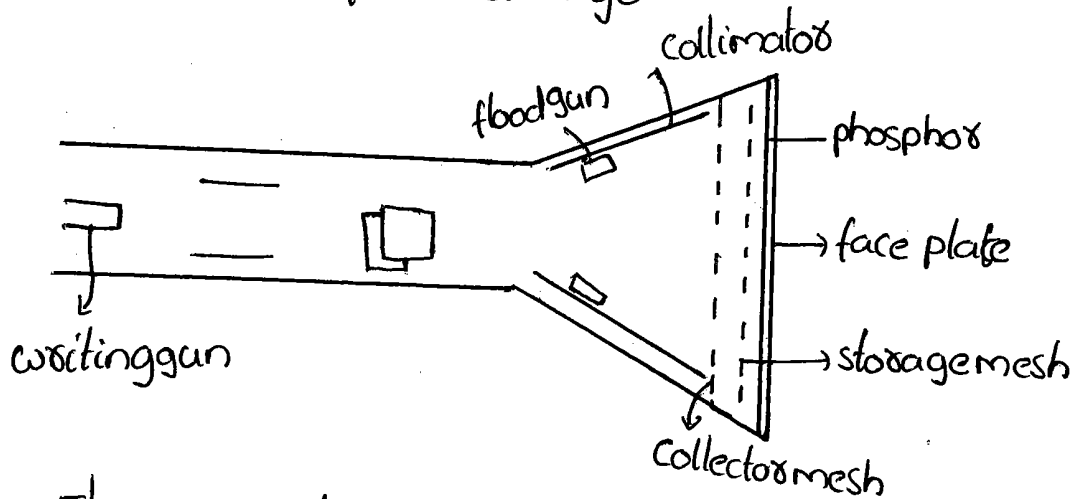

Fig shows an arrangement using a segmented multiple target, with a collector mesh in front through which the electrons can pass. Two guns are used, a high energy exciting gun, which emits a narrow beam of electrons & a flood gun which covers the target area with a continuous stream of low energy electrons. The flood gun remains on all the time, & maintains the target in either of the two stable states. The exciting gun is used to move the target from the lower to the upper stable state.

## Variable Persistence Storage

The variable persistence storage technique is also known as half-tone storage.



There are two screens, a storage mesh which retains the image traced on it by the writing gun, & the phosphor screen which is similar to that used in a conventional CRT.

Dielectric material, consisting of a thin layer of material such as magnesium fluoride, is deposited on the storage mesh & this acts as the storage target. The writing gun is at a high negative voltage, the flood gun at a few volts negative, the collector mesh at about 100V positive & the storage mesh at ground potential.

The collimator consists of a conductive coating on the inside surface of CRT. It is biased so as to distribute the flood gun electrons evenly over the surface of the target & causes the electrons to be perpendicular to the storage mesh.

When the writing gun is aimed at the storage target it causes areas where it strikes to be charged to a positive potential, due to secondary emission. These areas are maintained at their upper stable point, even after the writing gun is switched off, due to action of the flood gun. Electrons from the flood gun also pass through those areas which are positively charged, causing the phosphor beyond to glow & displaying the original signal traced by the writing gun.

The pattern stored on the storage target lasts for one hour, but it can display a bright image for about one minute. The stored pattern fades due to electrons from the flood gun charging other parts of the storage surface, giving an impression that the whole screen has been written. This is known as fading positive. To erase an image which has been stored the storage mesh is momentarily raised to the same positive potential as the collector mesh.

Variable persistence storage finds many applications, such as the storage of an entire waveform of a slow moving signal, which then fades before the next trace is written. It can also be used to store several traces before the first one fades, so as to see how the signal changes with time.

## Bistable Storage Oscilloscope

The bistable storage tube is between two & ten times slower than a comparable variable persistence tube. However it is capable of much longer storage times, measured in hours rather than in minutes as for variable persistence. The bistable tube is also capable of operating in a split screen mode, where half the screen has storage capability & the other half is a conventional phosphor tube.

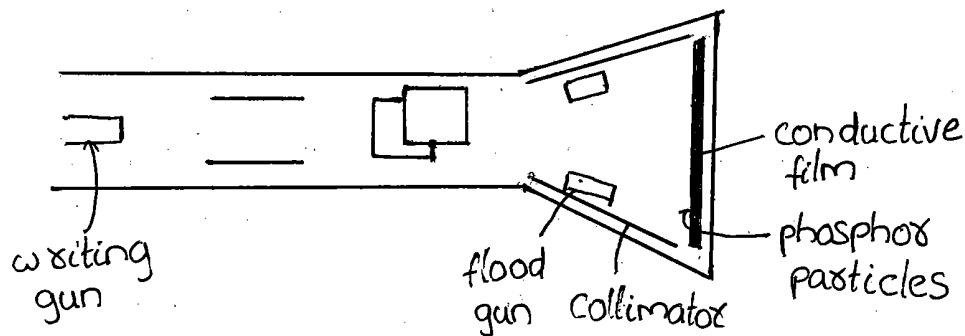

Fig shows the construction of a bistable storage tube. Unlike the variable persistence tube the same phosphor screen is used for both storage & display. The screen consists of P1 phosphor, doped to have good secondary emission characteristics & deposited on a conductive backplane made from a transparent metal film. The phosphor layer consists of a thin coating of scattered particles, so as to give a discontinuous surface. This stops the boundary migration of stored charge. The thin phosphor coating also has a short life since it suffers from light output reduction with time.

The conductive film is held at a low positive potential, so as to attract a cloud of low energy electrons

from the flood guns. These electrons have insufficient energy to penetrate the phosphor, & are gathered by the collimator. When the write gun is switched on, its high energy electrons result in secondary emission from areas traced on the screen, moving these to the upper stable point. The trace is therefore at a high positive potential & this is maintained due to low leakage of the phosphor.

The low energy electrons from the flood guns are now attracted to the positive areas of the screen & go through the phosphor to reach the metal film at the back. In passing through the phosphor they cause it to glow, displaying the area traced out by the writing gun. The screen can be erased by setting the metal film to a negative voltage, repelling the electrons back into the storage area, & returning the phosphor to the low stable point.

## Digital Read out oscilloscope

The digital read out oscilloscope consists of CRT display & a counter display.

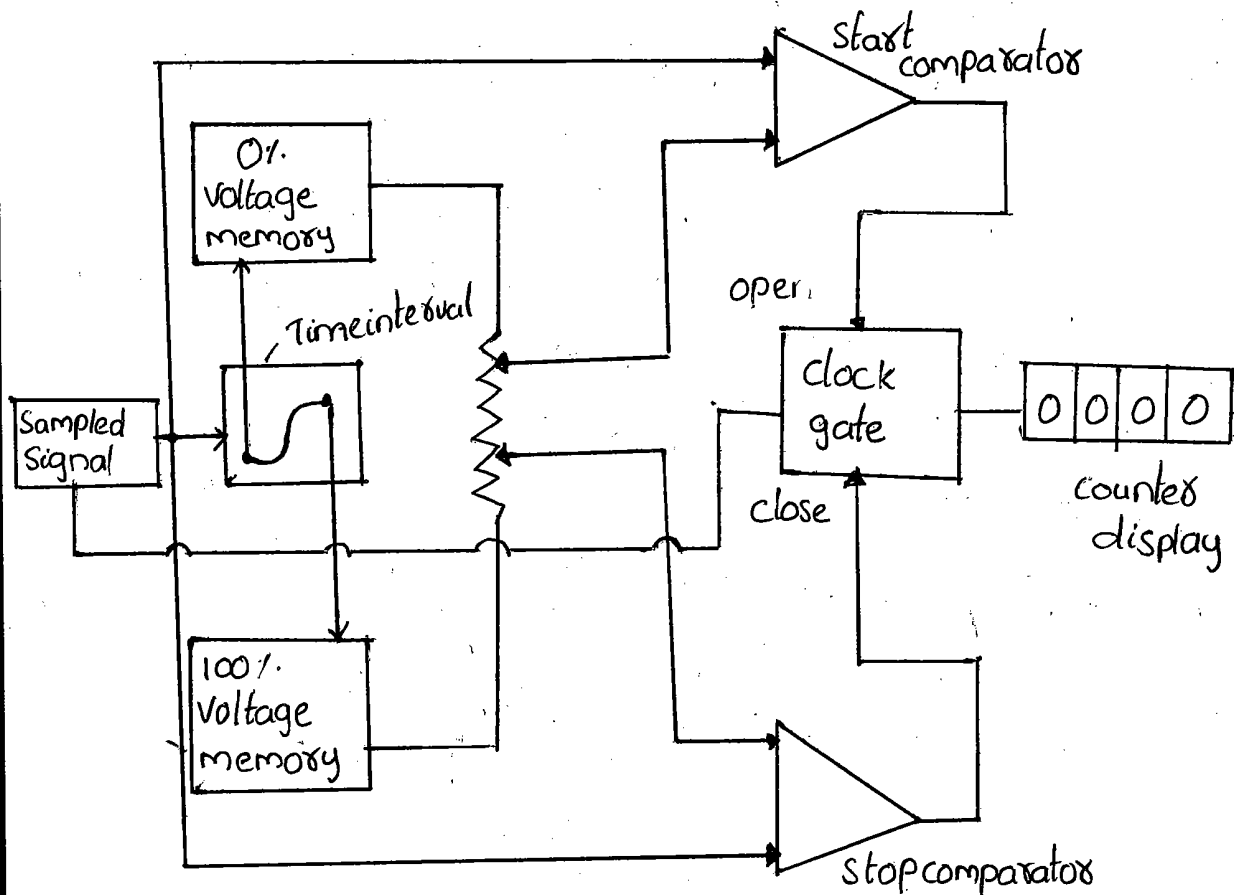

The input signal is first sampled using sampling circuit. The sampled signal is given as one output to each start & stop comparators. When input is sampled, the sampling circuit advances the sampling position by a fixed amount. This process is called strobing. The selected sweep time per cm control & number of samples taken per cm decide the equivalent time between two samples.

The CRT trace is used to identify 0% & 100% zone.

