

**R15**

Code No: 121AG

JAWAHARLAL NEHRU TECHNOLOGICAL UNIVERSITY HYDERABAD

B.Tech I Year Examinations, August/September - 2017

ENGINEERING DRAWING

(Common to ECE, EIE)

Time: 3 hours

Max Marks: 75

Answer any five questions

All questions carry equal marks

---

- 1.a) A map of size 500 cm × 50 cm wide represents an area of 6250 Sq.Kms. Construct a vernier scale to measure kilometers, hectometers and decameters and long enough to measure up to 7 km. Indicate on it i) 5.33 km ii) 59 decameters.
- b) A thin triangular equilateral plate of 20 mm side is pinned at its centroid O. An in elastic string circumscribes complete perimeter of the plate. One end of the string is attached to one of the apex of the plate. Draw the curve traced out by other end of the string keeping it tight when the string is unwound. [7+8]

OR

- 2.a) A rectangular plot of land measuring 1.28 hectares is represented on a map by a similar rectangle of 8 Sq.cm. Calculate RF of the scale. Draw a diagonal scale to read single meter. Show a distance of 438 m on it.
- b) Point F is 50 mm from a line AB. A point is moving in a plane such that the ratio of its distances from F and line AB remains constant and equals to 2/3. Draw locus of point P. [7+8]

- 3.a) A Point Q is situated in first quadrant. It is 40 mm above H.P and 30 mm in front of V.P. Draw its projections and find its shortest distance from the intersection of H.P, V.P and auxiliary Plane.
- b) A straight road going uphill from a point A, due east to another point B is 4 km long and has a slope of 15°. Another straight road from B, due 30° east of north, to point C is also 4 km long but is on ground level. Determine the length and slope of the straight road joining the points A and C. Scale 10 mm = 0.4 km. [7+8]

OR

- 4.a) A pentagonal plane of 45 mm side has a circular hole of 40mm diameter in its centre. The plane stands on one of its sides on the H.P with its plane perpendicular to V.P and 45° inclined to the H.P. Draw its projections.
- b) Draw the projections of regular pentagon of 40 mm wide having its surface inclined at 30° to the H.P makes an angle of 60° with the V.P. Draw its Projections? [7+8]

- 5.a) A cone base of 70 mm diameter, axis 75 mm long and resting on its base on the H.P., is cut by a vertical section plane, the H.T of which make an angle of 60° with the reference line and is 12 mm away from the top view of the axis. i) Draw the sectional front view and the true shape of the section ii) also draw the sectional front view and the top view when the same section plane is parallel to the V.P.
- b) A Square pyramid base 50 mm side and axis 75 mm long is resting on the H.P on its triangular faces, the top view of the axis making an angle of 30° with the V.P. It is cut by a horizontal section plane, the vertical trace of which intersects the axis at a point 6 mm from the base. Draw the front view, sectional top view and the development of sectioned pyramid. [7+8]

OR

- 6.a) A Square pyramid of 50 mm side of base and 50 mm length of axis is resting on one of its triangular faces on the H.P having a slant edge containing that face parallel to the V.P. Draw the projections of the pyramid.
- b) A regular pentagonal pyramid with the sides of its base 30 mm and height 80 mm rests on an edge off the base. The base is tilted until its apex is 50 mm above the level of the edge of the base on which it rests. Draw the projection of the pyramid when the edge on which it rests is parallel to the V.P and the apex of the pyramid points towards V.P. [7+8]
- 7.a) A vertical square prism base 50 mm side and height 90 mm has a face inclined at  $30^\circ$  to the V.P. It is completely penetrated by another square prism, base 38 mm side and axis 100 mm long, faces of which are equally inclined to the V.P. The axes of the two prisms are parallel to the V.P and bisect each other at right angles. Draw the projections showing lines of intersection.
- b) A vertical cylinder of 80 mm diameter is completely penetrated by another cylinder of 60 mm diameter their axes bisecting each other at right angles. Draw their projections showing curves of penetration, assuming the axis of the penetrating cylinder to be parallel to the V.P. [7+8]
- OR**
- 8.a) A cylinder of 60 mm diameter, having its axis vertical is penetrated by another cylinder of 40 mm diameter. The axis of penetrating cylinder is parallel to the V.P and bisects the axis of the vertical cylinder making an angle of  $60^\circ$  with it. Draw the projections showing curves of intersection.
- b) A pentagonal prism 30 mm side and 50 mm axis is standing on H.P on its base whose one side is perpendicular to V.P. It is cut by a section plane  $45^\circ$  inclined to H.P through midpoint of axis. Draw front view, sectional top view, and sectional side view. Also draw true shape of the section and development of surface of remaining solid. [7+8]
- 9.a) A square pyramid of 30 mm base sides and 50 mm long axis is centrally placed on the top of a cube of 50 mm long edges. Draw isometric view of the pair.
- b) A square pyramid of 40 mm base sides and 60 mm axis is cut by an inclined section plane through midpoint of axis as shown in figure 1. Draw its Isometric View of the section of pyramid? All dimensions are in mm. [7+8]

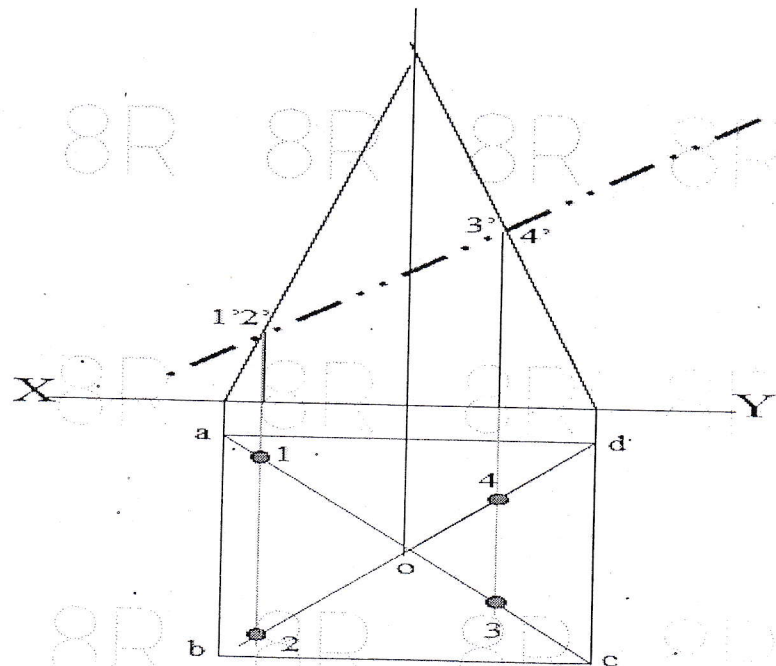

Figure: 1

OR

- 10.a) The front view and Top view of the object given in figure 2. Draw its isometric view. All dimensions are in mm.

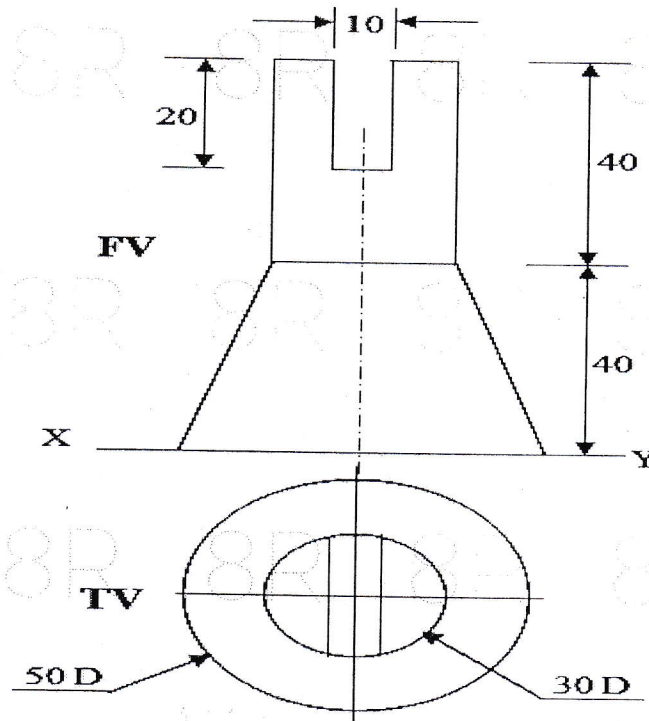

Figure: 2

- b) Draw the perspective view of a cube of 80 mm side having its one corner of the edge on the ground plane and the other corner of the edge resting on the picture plane such that the edge is inclined at  $30^\circ$  to the picture plane. The other two edges of the corner are equally inclined with the picture plane. The station point is 100 mm in front of the picture plane, 150 mm above the ground plane and lies in a central plane which passes through the centre of the cube.

[8+7]

---ooOoo---