

Code No: 115DU

**JAWAHARLAL NEHRU TECHNOLOGICAL UNIVERSITY HYDERABAD**  
**B. Tech III Year I Semester Examinations, November/December - 2016**  
**CONTROL SYSTEMS ENGINEERING**  
 (Common to ECE, ETM)

Time: 3 hours

Max. Marks: 75

**Note:** This question paper contains two parts A and B.  
 Part A is compulsory which carries 25 marks. Answer all questions in Part A. Part B consists of 5 Units. Answer any one full question from each unit. Each question carries 10 marks and may have a, b, c as sub questions.

**PART - A**

(25 Marks)

- 1.a) Give the Mason's Gain formula. [2]
- b) List out the classification of control systems. [3]
- c) What is meant by un-damped response? [2]
- d) Write the effects of proportional derivative systems on second order response. [3]
- e) What is the need of angle of asymptotes in Root-locus? [2]
- f) Write the remedies if an entire row is zero while computing elements in R-H array. [3]
- g) Draw the pole-zero plot of Lag compensator. [2]
- h) Define gain-cross over frequency and phase-cross over frequency. [3]
- i) Draw the state diagram of a state model. [2]
- j) What is meant by diagonalization? Explain. [3]

**PART - B**

(50 Marks)

- 2.a) Discuss the characteristics of feedback in closed loop control system.
- b) Define the Impulse response of the system. Also find the impulse response of the system with open loop transfer function. [5+5]

$$G(s) = \frac{10}{s(s+3)}$$

**OR**

3. Obtain the transfer function  $\frac{Y(s)}{R(s)}$  for the following block diagram (figure 1): [10]

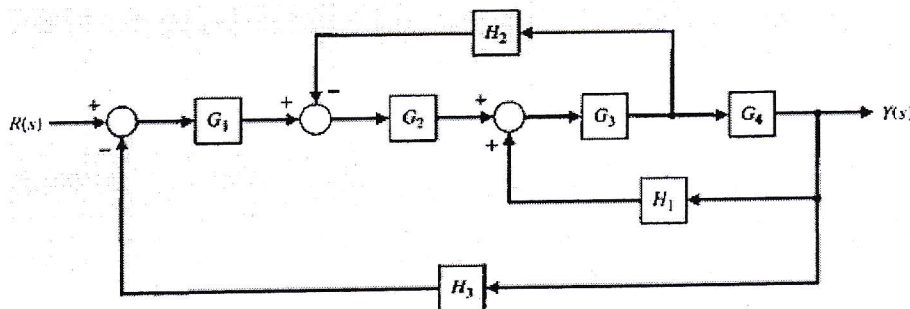

Figure 1

- 4.a) Sketch the time response of the following figure 2 first order system when excited with unit step input.

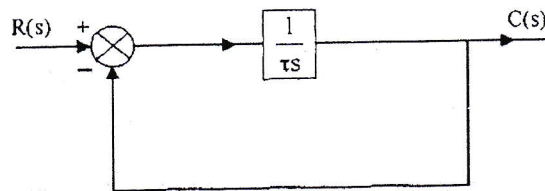

Figure 2

- b) A second order system has a transfer function  $G(s) = \frac{25}{(s^2 + 8s + 25)}$ , Determine the settling time and peak overshoot when the system is excited with unit step input. [5+5]

OR

- 5.a) Find the steady state errors for the unit step, unit ramp and unit parabolic inputs for the system whose transfer function is  $G(s) = \frac{1000(s+1)}{(s+10)(s+50)}$

- b) Discuss the significance of 'type' and 'order' of the system in time response analysis. [6+4]

6. Define Root locus and explain procedure to sketch the Root-locus for a given transfer function. [10]

OR

- 7.a) Comment on system stability if the characteristic equation of closed loop system is  $Q(s) = s^4 + 8s^3 + 18s^2 + 16s + 5 = 0$

- b) A unity feedback system with open loop transfer function  $G(s) = \frac{K}{s(s+1)}$ . Determine the range of 'K' for which system to be stable. [5+5]

8. Sketch the Bode plot for the unity feedback system with open loop transfer function

$$G(s) = \frac{80}{s(s+2)(s+20)}$$

Also find its gain margin and phase margin. [10]

OR

- 9.a) State and explain Nyquist stability criterion.

- b) What is PID controller and write its merits and demerits. [5+5]

- 10.a) What is state transition matrix and derive its expression.

- b) Obtain the state model for the system which is described as

$$\frac{d^2y}{dt^2} + 5\frac{dy}{dt} + 10y(t) = 5u(t)$$

Here, 'y' is output variable and 'u' is input variable. [4+6]

OR

- 11.a) Explain the concept of controllability and observability.

- b) Write the advantages of state space analysis over transfer function approach. [5+5]

---ooOoo---