

Lecture 12 - Digital Circuits (I)

THE INVERTER

October 20, 2005

Contents:

1. Introduction to digital electronics: the inverter
2. NMOS inverter with resistor pull up

Reading assignment:

Howe and Sodini, Ch. 5, §§5.1-5.3.2

Key questions

- What are the key figures of merit of logic circuits?
- How can one make a simple inverter using a single MOSFET?

1. Introduction to digital electronics: the inverter

In digital electronics, digitally-encoded information is represented by means of two distinct voltage ranges:

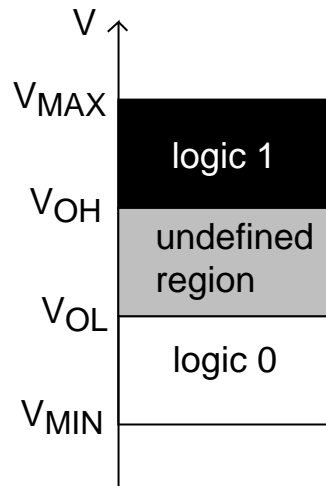

- *logic 0*: $V_{MIN} \leq V \leq V_{OL}$
- *logic 1*: $V_{OH} \leq V \leq V_{MAX}$
- *undefined logic value*: $V_{OL} \leq V \leq V_{OH}$.

Logic operations are performed using *logic gates*.

Simplest logic operation of all: *inversion* \Rightarrow inverter

□ Ideal inverter:

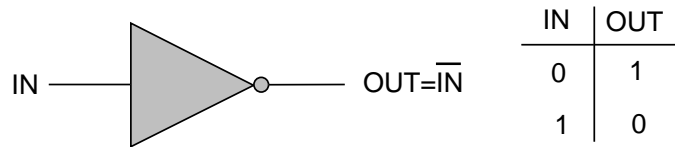

Circuit representation and ideal transfer function:

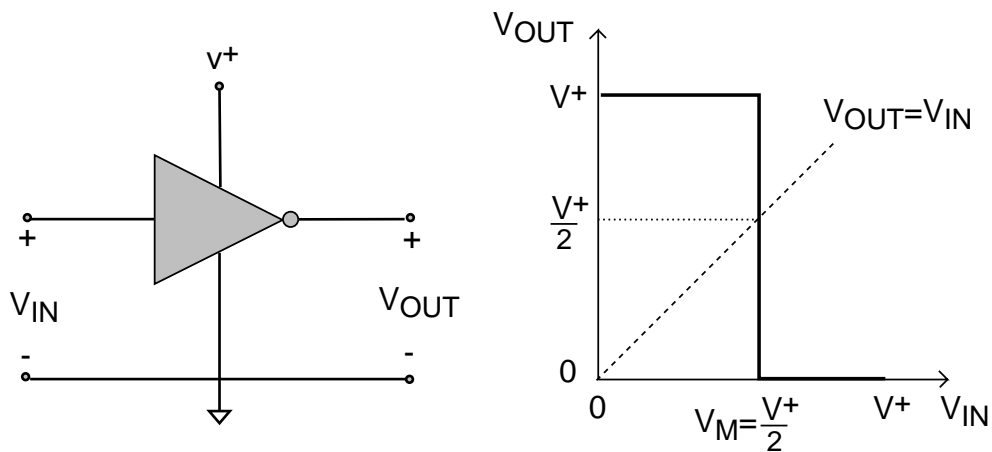

Define *switching point* or *logic threshold*:

$$V_M \equiv \text{input voltage for which } V_{OUT} = V_{IN}$$

$$\text{-for } 0 \leq V_{IN} \leq V_M \quad \Rightarrow \quad V_{OUT} = V^+$$

$$\text{-for } V_M \leq V_{IN} \leq V^+ \quad \Rightarrow \quad V_{OUT} = 0$$

Key property of ideal inverter: *signal regeneration*

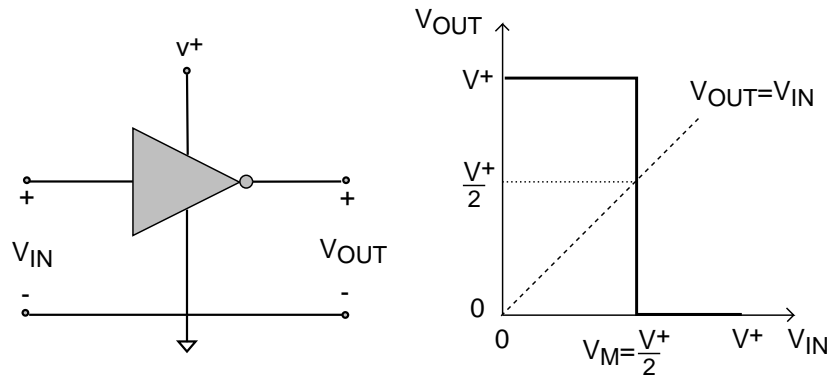

Ideal inverter returns well defined logical outputs (0 or V^+) even in the presence of considerable noise in V_{IN} (from voltage spikes, crosstalk, etc.)

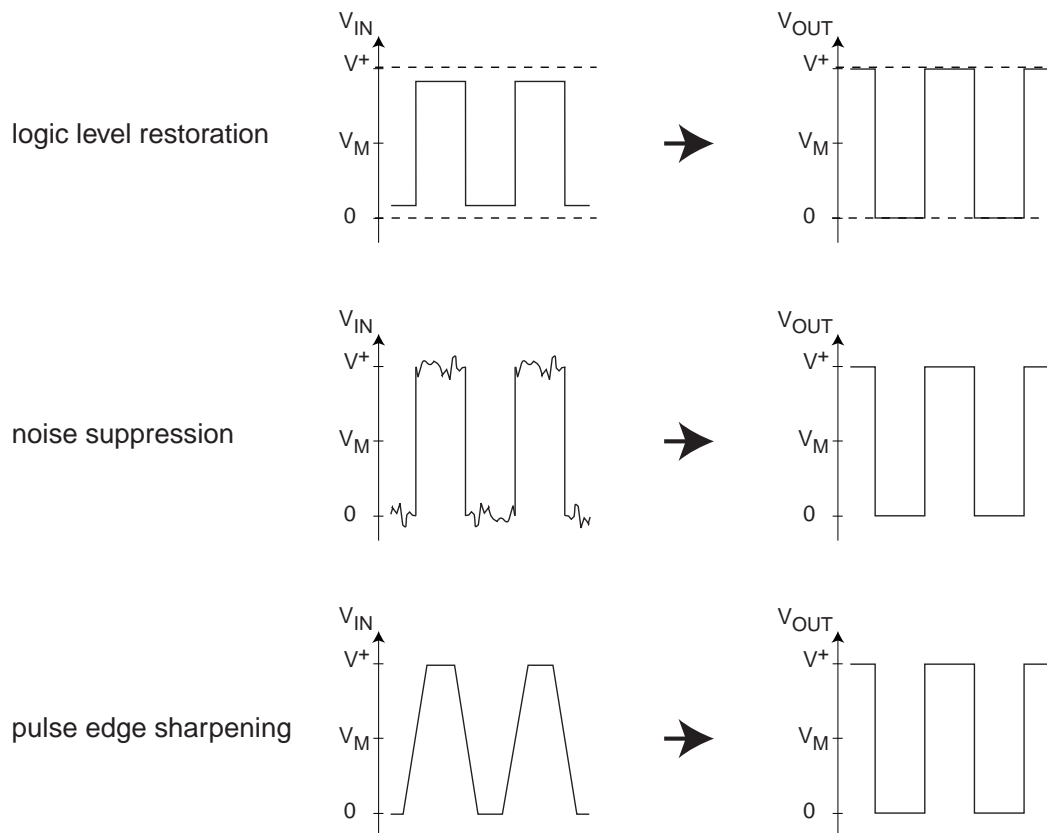

□ "Real" inverter:

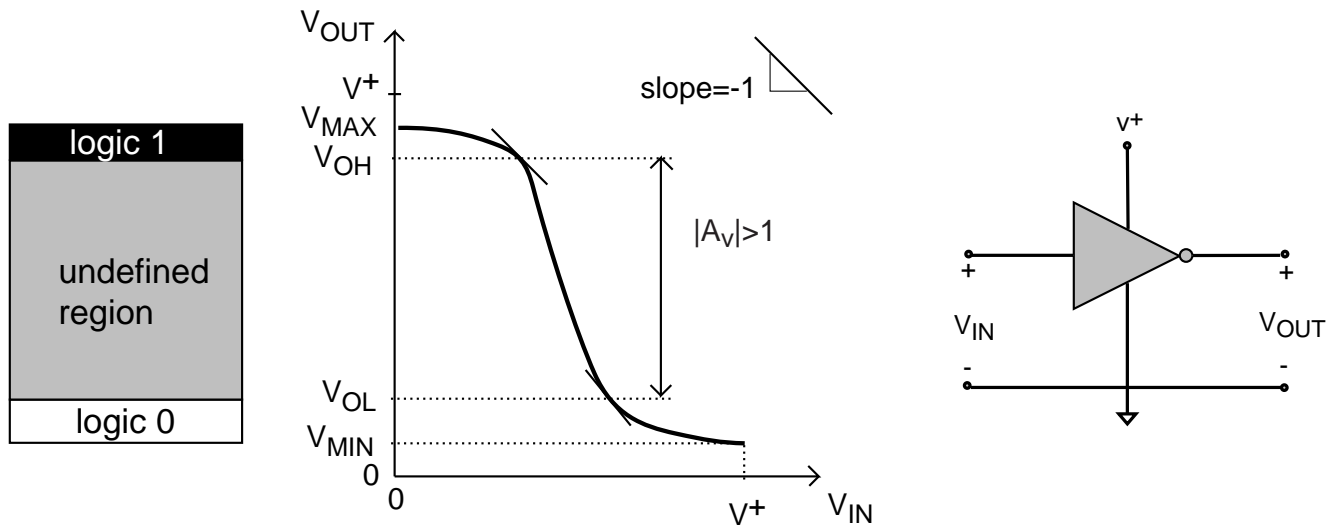

In a real inverter, valid logic levels defined as follows:

- *logic 0:*

$V_{MIN} \equiv$ output voltage when $V_{IN} = V^+$

$V_{OL} \equiv$ smallest output voltage where slope=-1

- *logic 1:*

$V_{OH} \equiv$ largest output voltage where slope=-1

$V_{MAX} \equiv$ output voltage when $V_{IN} = 0$

Two other important voltages:

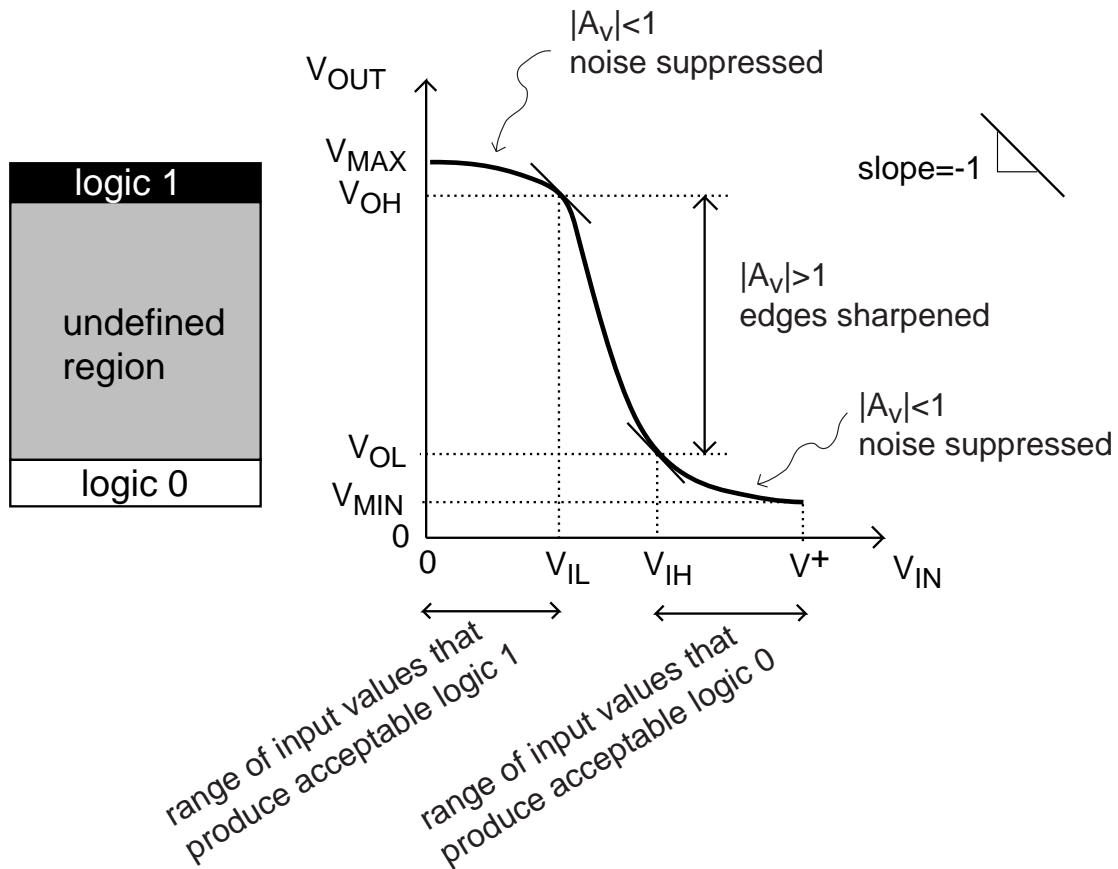

$V_{IL} \equiv$ smallest input voltage where slope= -1

$V_{IH} \equiv$ highest input voltage where slope= -1

To have *signal regeneration*:

range of input values that produce acceptable logic output
 $>$ range of valid logic values

Key to signal regeneration in inverter: *high voltage gain*

Quantify signal regeneration through *noise margins*.

Consider chain of two inverters:

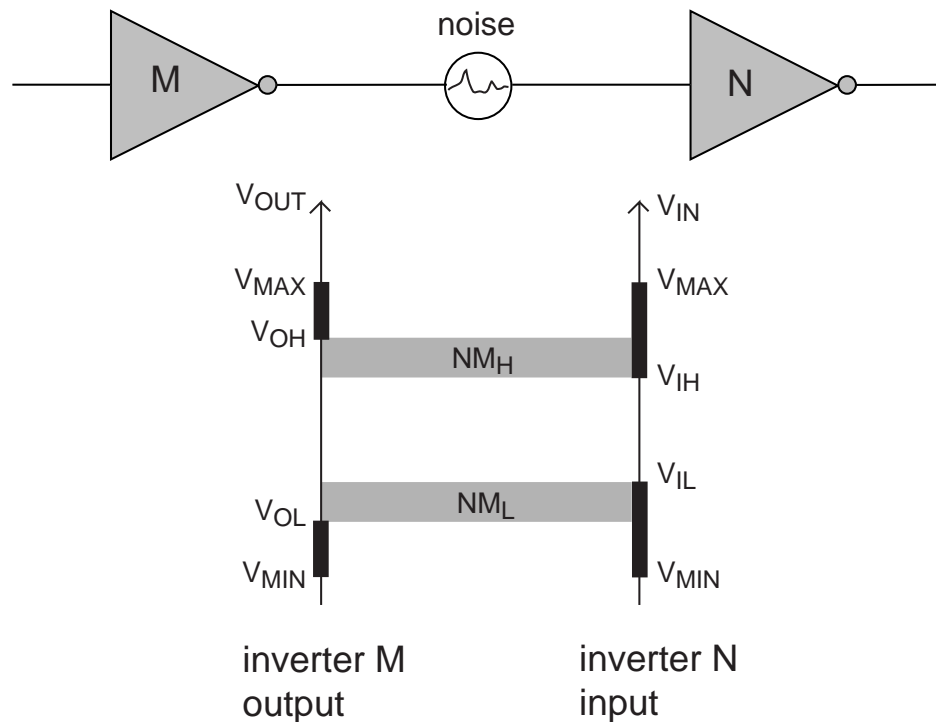

Define *noise margins*:

$$NM_H = V_{OH} - V_{IH} \quad \text{noise margin high}$$

$$NM_L = V_{IL} - V_{OL} \quad \text{noise margin low}$$

When signal is within noise margins:

- logic 1 output from first inverter interpreted as logic 1 input by second inverter
- logic 0 output from first inverter interpreted as logic 0 input by second inverter

Simplifications for hand calculations

Hard to compute $A_v = -1$ points in transfer function.

Approximate calculation:

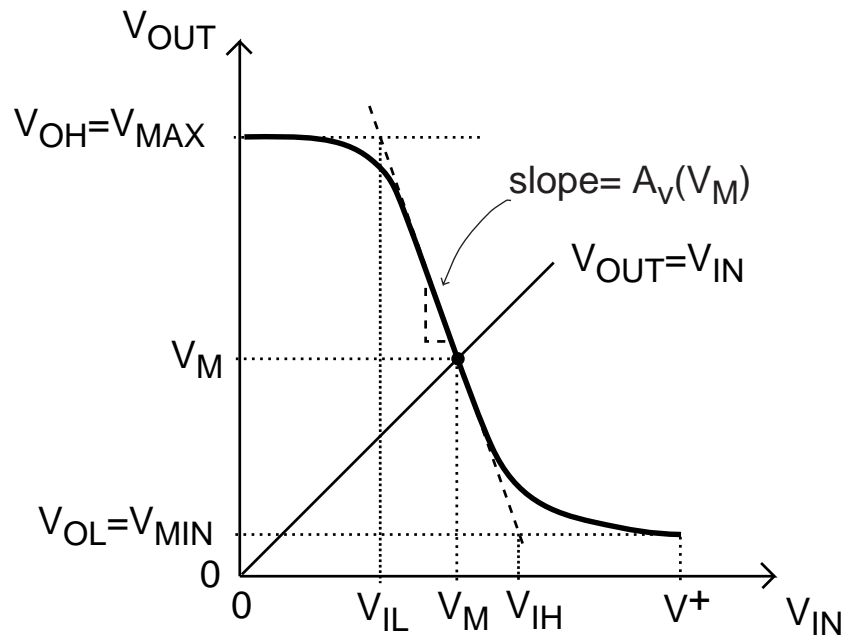

- Assume $V_{OL} \simeq V_{MIN}$ and $V_{OH} \simeq V_{MAX}$
- Trace tangent of transfer function at V_M
(slope=small signal voltage gain at V_M)
- $V_{IL} \simeq$ intersection of tangent with $V_{OUT} = V_{MAX}$
- $V_{IH} \simeq$ intersection of tangent with $V_{OUT} = V_{MIN}$
- to enhance noise margin: $|A_v(V_M)| \uparrow$

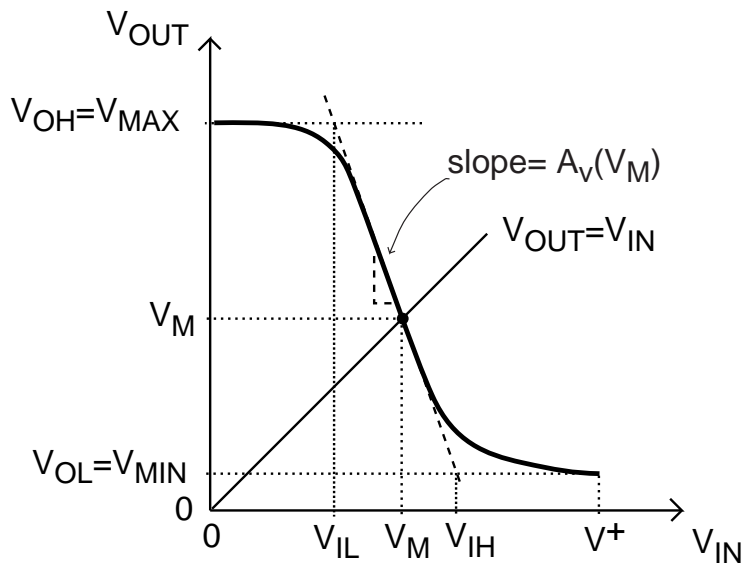

$$|A_v(V_M)| \simeq \frac{V_{MAX} - V_M}{V_M - V_{IL}} \Rightarrow V_{IL} \simeq V_M - \frac{V_{MAX} - V_M}{|A_v(V_M)|}$$

$$|A_v(V_M)| \simeq \frac{V_M - V_{MIN}}{V_{IH} - V_M} \Rightarrow V_{IH} \simeq V_M \left(1 + \frac{1}{|A_v(V_M)|}\right) + \frac{V_{MIN}}{|A_v(V_M)|}$$

Then:

$$NM_L = V_{IL} - V_{OL} \simeq (V_{MAX} - V_{MIN}) - (V_{MAX} - V_M) \left(1 + \frac{1}{|A_v(V_M)|}\right)$$

$$NM_H = V_{OH} - V_{IH} \simeq (V_{MAX} - V_{MIN}) - (V_M - V_{MIN}) \left(1 + \frac{1}{|A_v(V_M)|}\right)$$

If $|A_v(V_M)| \rightarrow \infty$:

$$NM_L \rightarrow V_M - V_{MIN} \quad NM_H \rightarrow V_{MAX} - V_M$$

□ Transient characteristics

Look at inverter switching in the time domain:

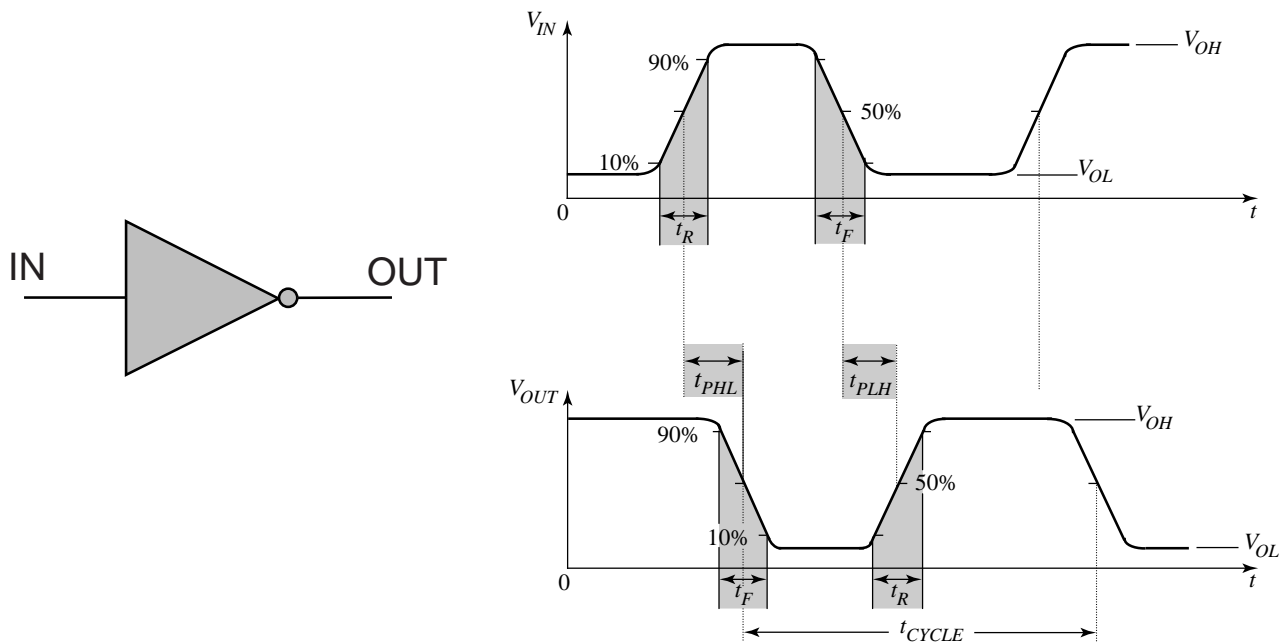

$t_R \equiv$ rise time between 10% and 90% of total swing

$t_F \equiv$ fall time between 90% and 10% of total swing

$t_{PHL} \equiv$ propagation delay from high-to-low between 50% points

$t_{PLH} \equiv$ propagation delay from low-to-high between 50% points

Propagation delay: $t_P = \frac{1}{2}(t_{PHL} + t_{PLH})$

Propagation delay: simplification for hand calculations

- Input wavefunction = ideal square wave
- Propagation delay times = delay times to 50% point

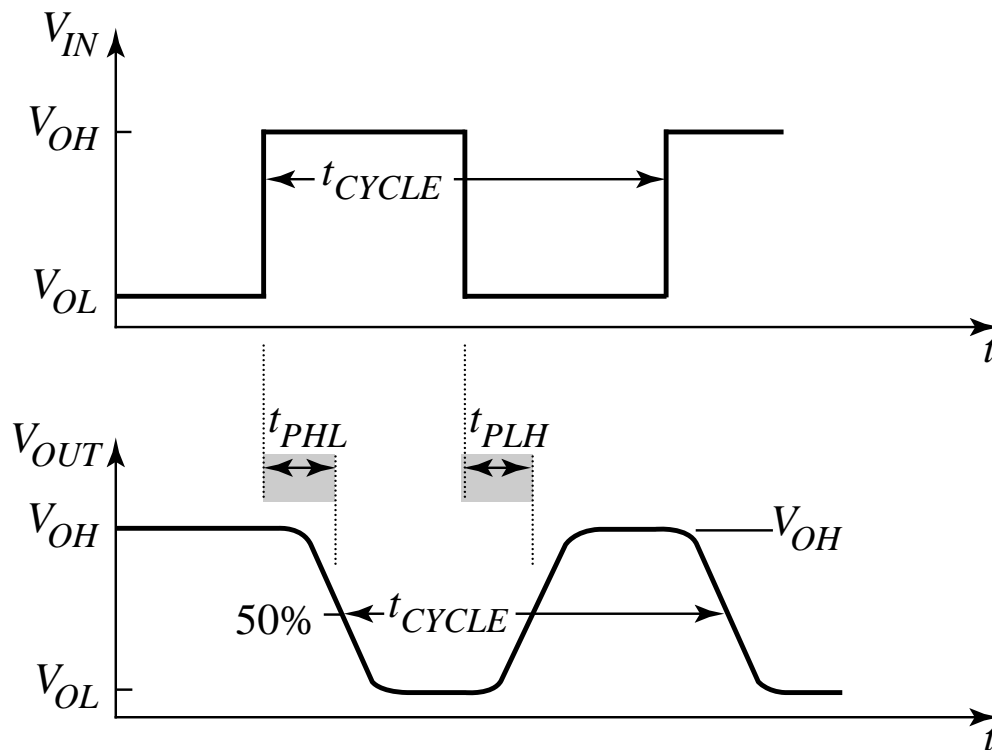

- Hand calculations only approximate
- SPICE essential for accurate delay analysis

2. NMOS inverter with resistor pull up

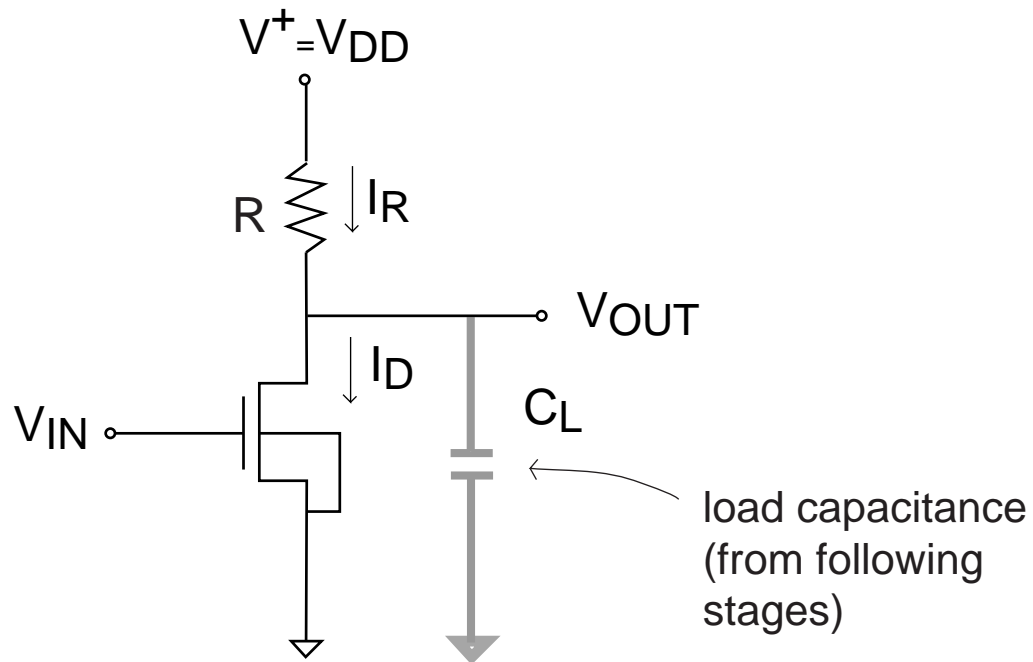

Features:

- $V_{BS} = 0$ (typically not shown)
- C_L summarizes capacitive loading of following stages (other logic gates, interconnect lines)

Basic operation:

- if $V_{IN} < V_T$, MOSFET OFF $\Rightarrow V_{OUT} = V_{DD}$
- if $V_{IN} > V_T$, MOSFET ON $\Rightarrow V_{OUT}$ small (value set by resistor/nMOS divider)

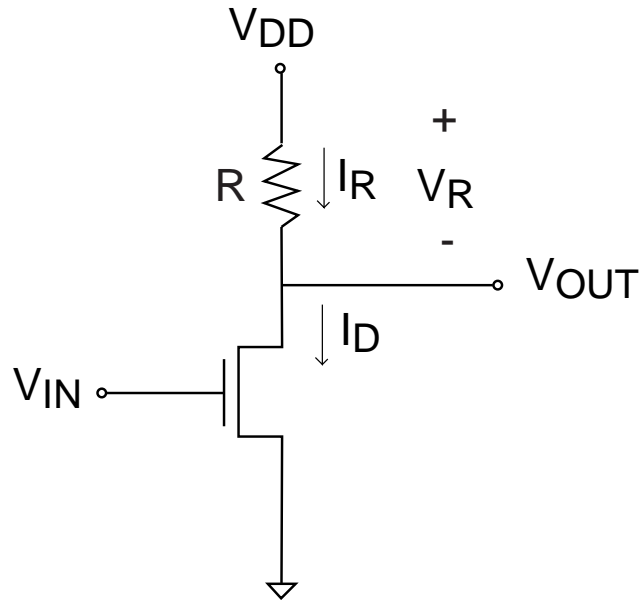

Transfer function obtained by solving:

$$I_R = I_D$$

Can solve graphically: I-V characteristics of pull-up resistor on I_D vs. V_{OUT} transistor characteristics:

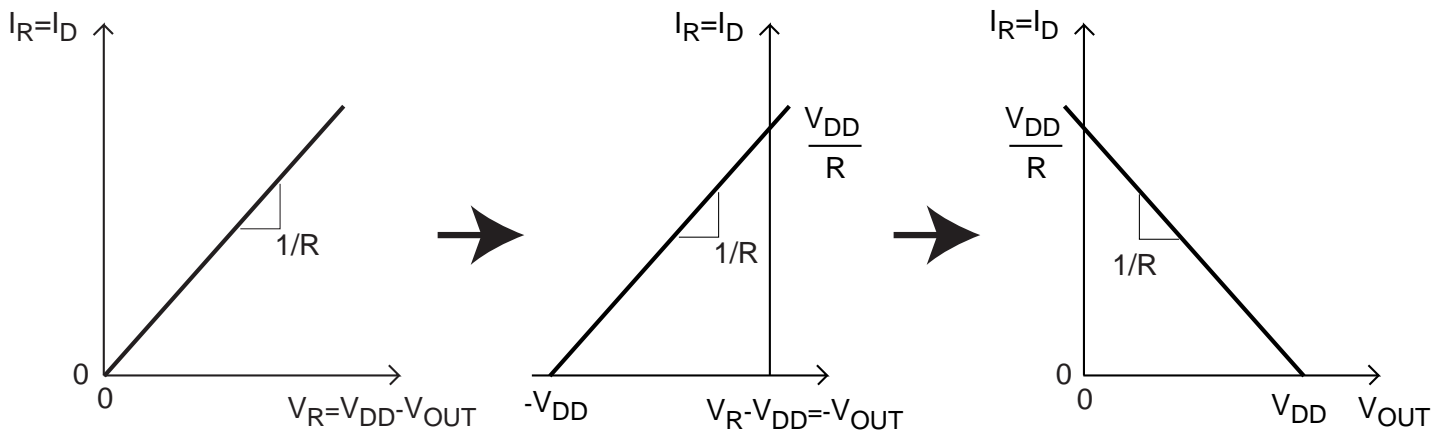

Overlap I-V characteristics of resistor pull-up on I-V characteristics of transistor:

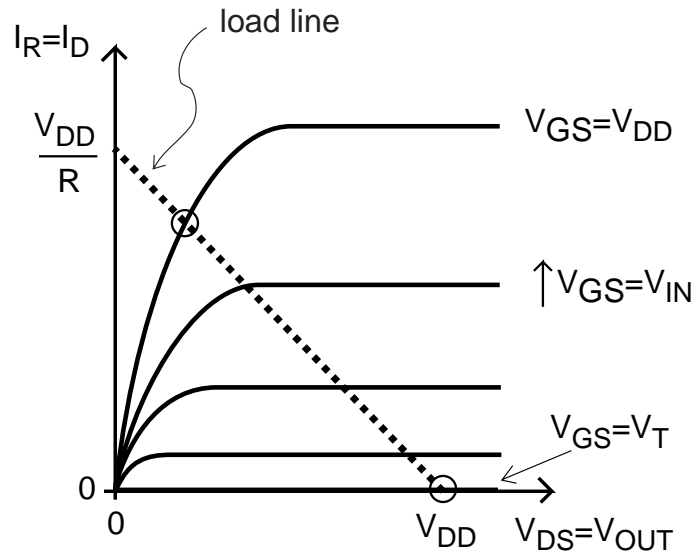

Transfer function:

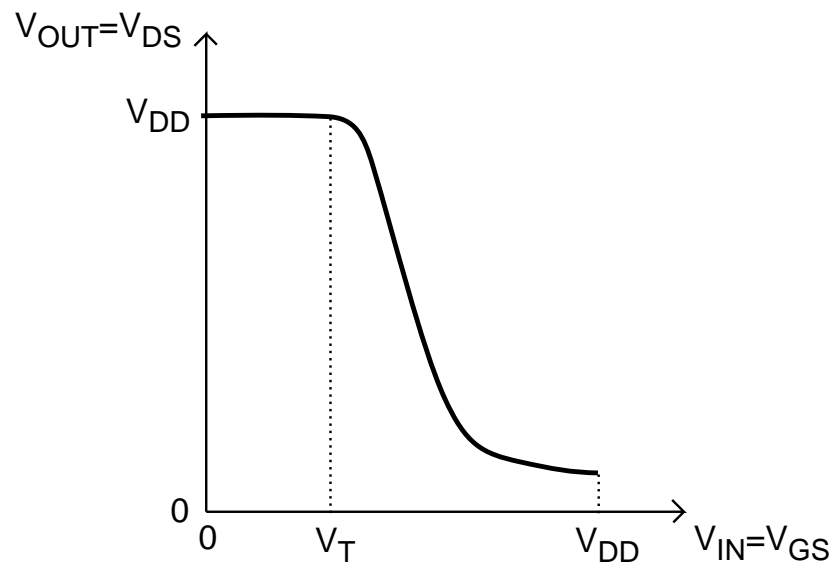

Logic levels:

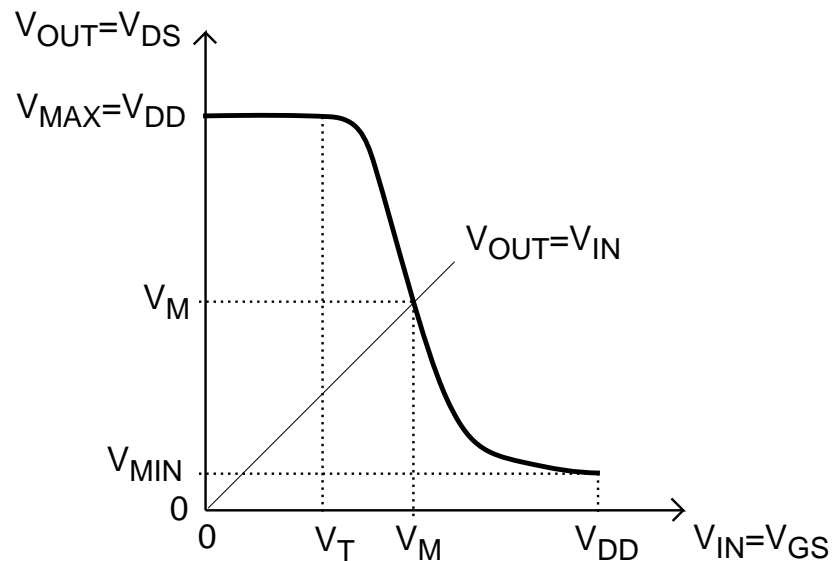

For V_{MAX} , transistor is cut-off, $I_D = 0$:

$$V_{MAX} = V_{DD}$$

For V_{MIN} , transistor is in linear regime; solve:

$$I_D = \frac{W}{L} \mu_n C_{ox} \left(V_{DD} - \frac{V_{MIN}}{2} - V_T \right) V_{MIN} = I_R = \frac{V_{DD} - V_{MIN}}{R}$$

For V_M , transistor is in saturation; solve:

$$I_D = \frac{W}{2L} \mu_n C_{ox} (V_M - V_T)^2 = I_R = \frac{V_{DD} - V_M}{R}$$

Will continue next lecture with analysis of noise margin and dynamics...

Key conclusions

- Logic circuits must exhibit *noise margins* in which they are immune to noise in input signal.
- Logic circuits must be *regenerative*: able to restore clean logic values even if input is noisy.
- *Propagation delay*: time for logic gate to perform its function.
- Concept of *load line*: graphical technique to visualize transfer characteristics of inverter.
- First-order solution (by hand) of inverter figures of merit easy if regimes of operation of transistor are correctly identified.
- For more accurate solutions, use SPICE (or other circuit CAD tool).