

6.003: Signals and Systems

CT Feedback and Control

March 18, 2010

Feedback and Control

Feedback: simple, elegant, and robust framework for control.

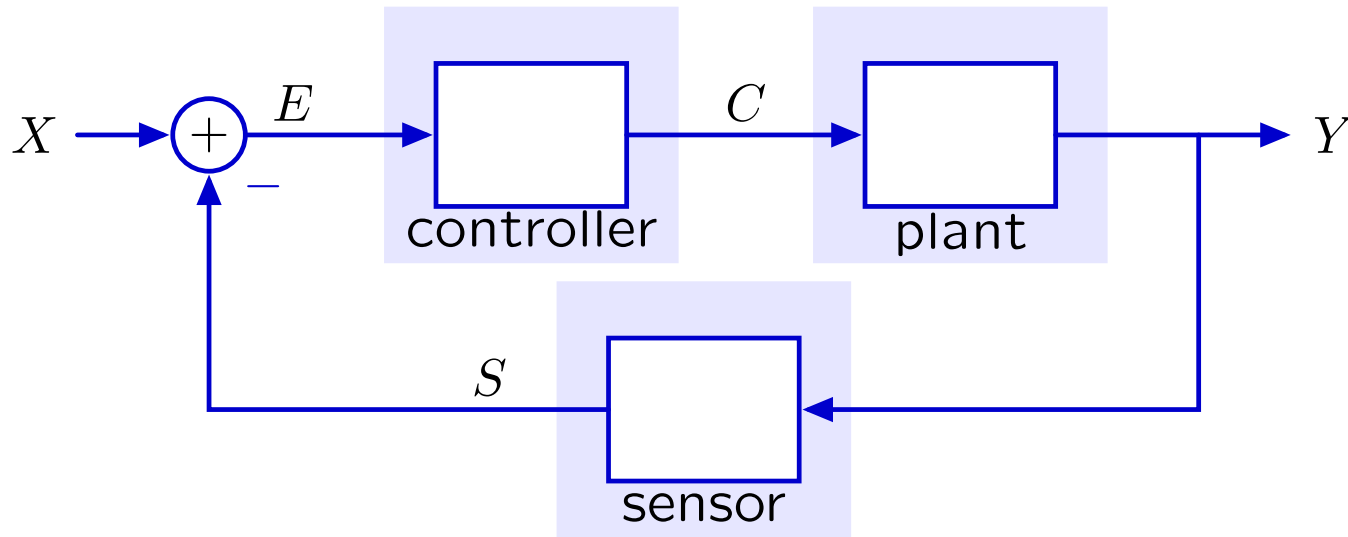

We started with robotic driving.

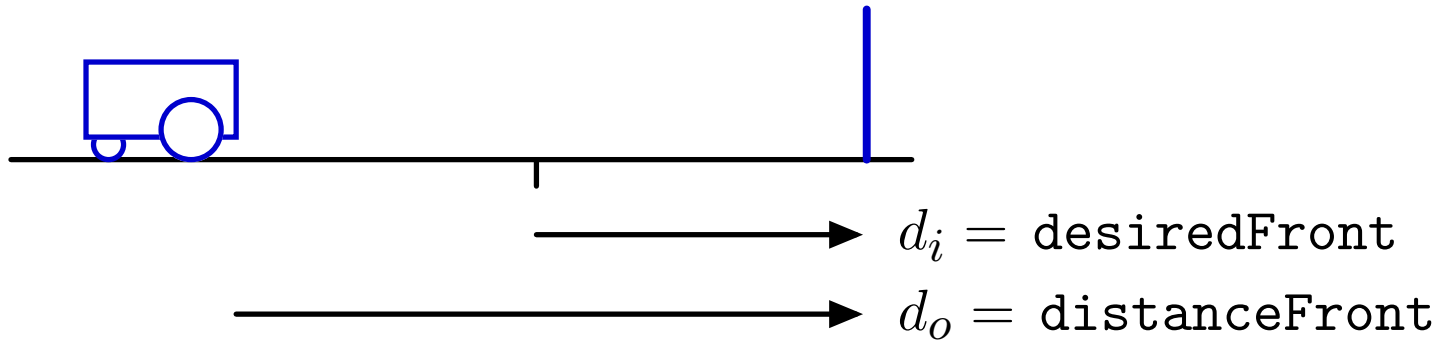

Feedback and Control

Using feedback to enhance performance.

Examples:

- improve performance of an op amp circuit.
- control position of a motor.
- reduce sensitivity to unwanted parameter variation.
- reduce distortions.
- stabilize unstable systems
 - magnetic levitation
 - inverted pendulum

Feedback and Control

Reducing sensitivity to unwanted parameter variation.

Example: power amplifier

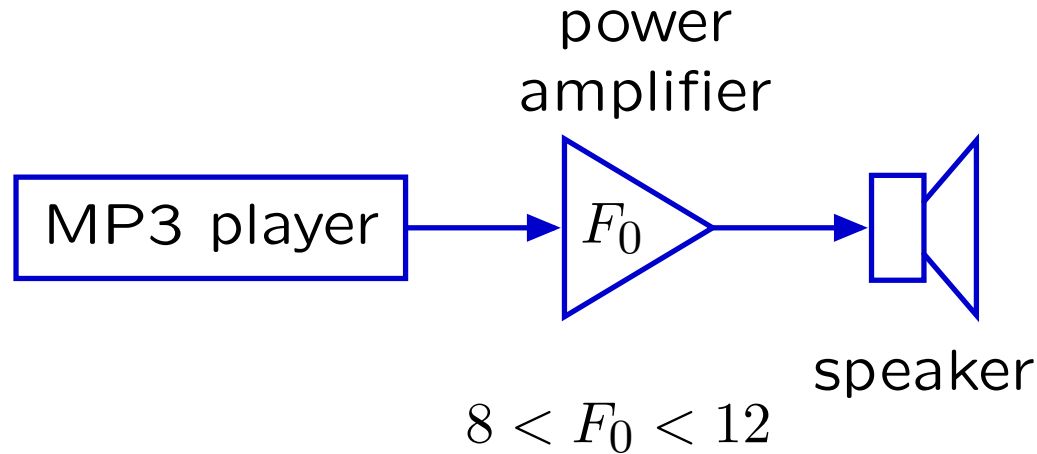

Changes in F_0 (due to changes in temperature, for example) lead to undesired changes in sound level.

Feedback and Control

Feedback can be used to compensate for parameter variation.

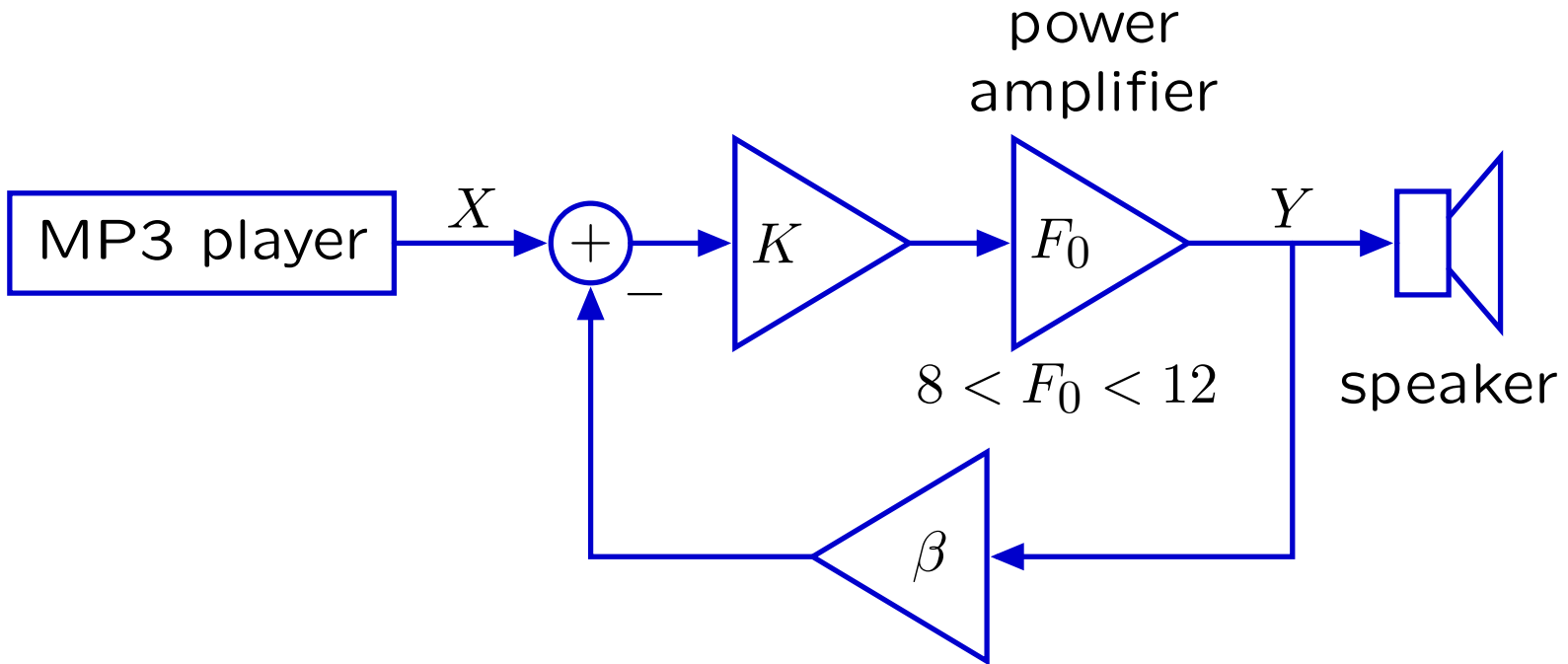

$$H(s) = \frac{KF_0}{1 + \beta KF_0}$$

If K is made large, so that $\beta KF_0 \gg 1$, then

$$H(s) \approx \frac{1}{\beta}$$

independent of K or F_0 !

Feedback and Control

Feedback reduces the change in gain due to change in F_0 .

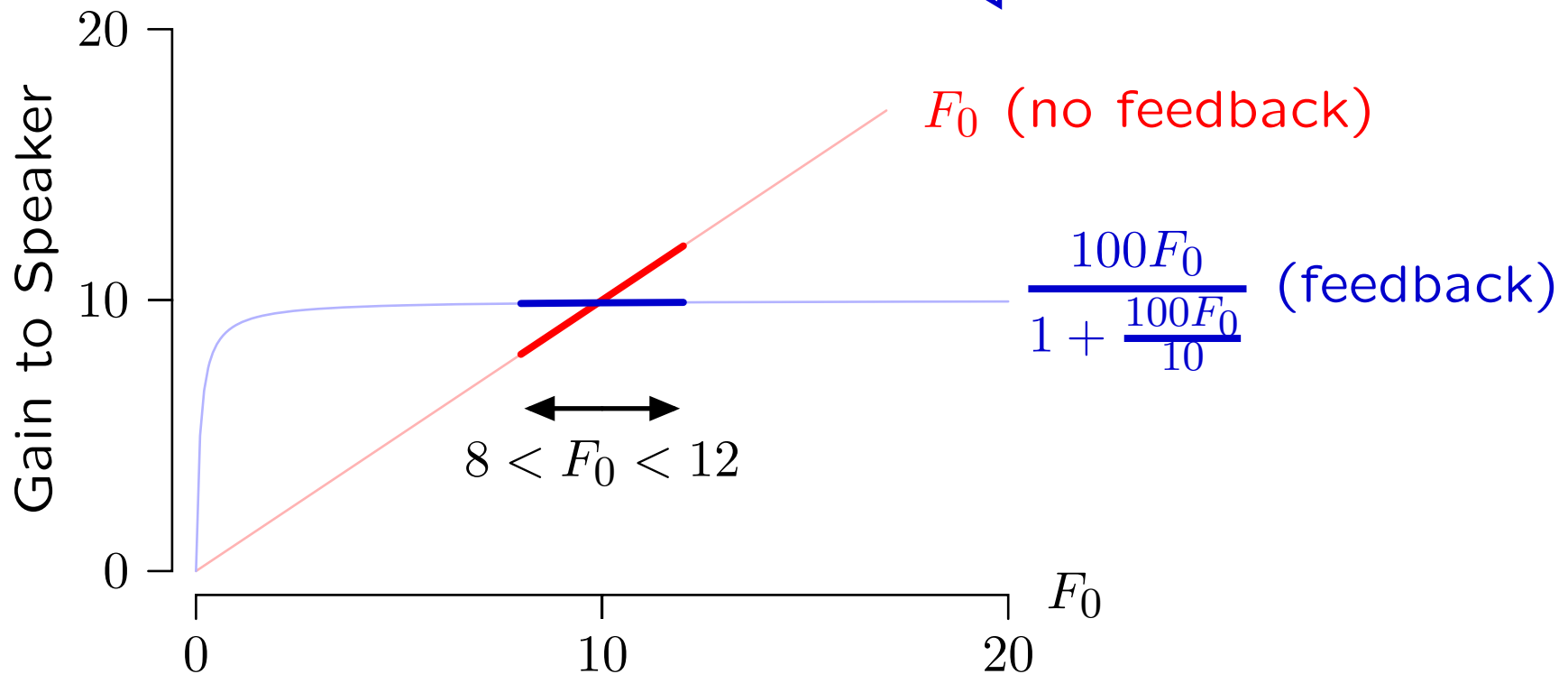
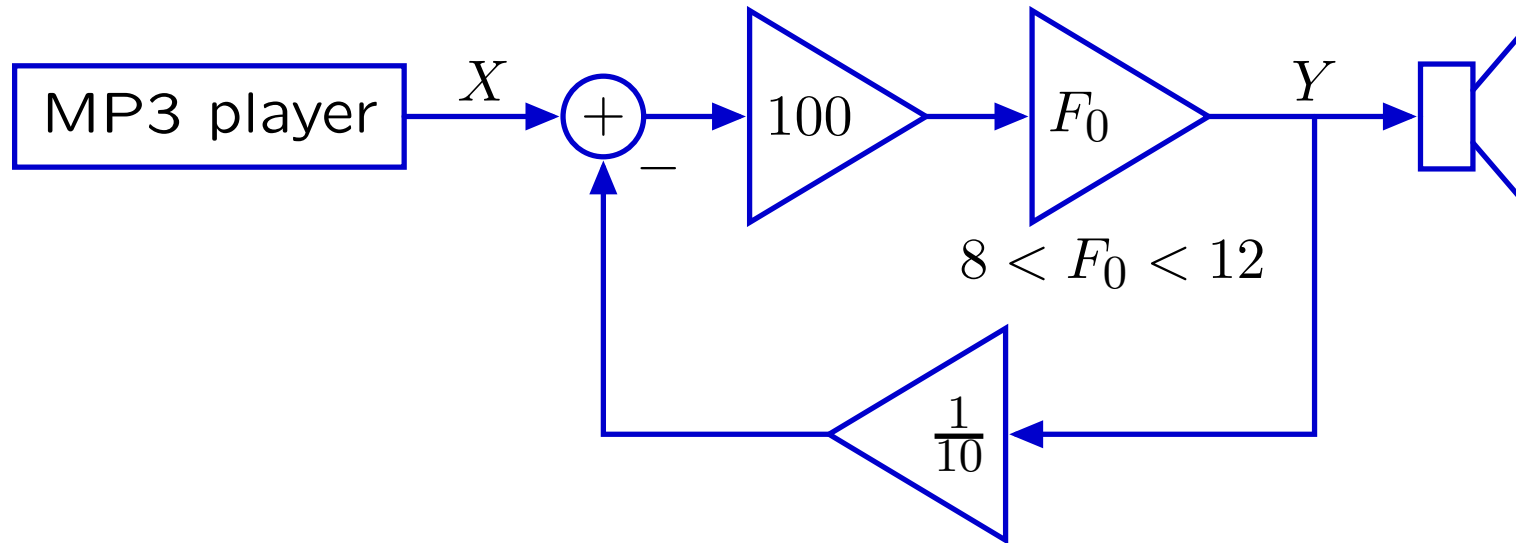

Check Yourself

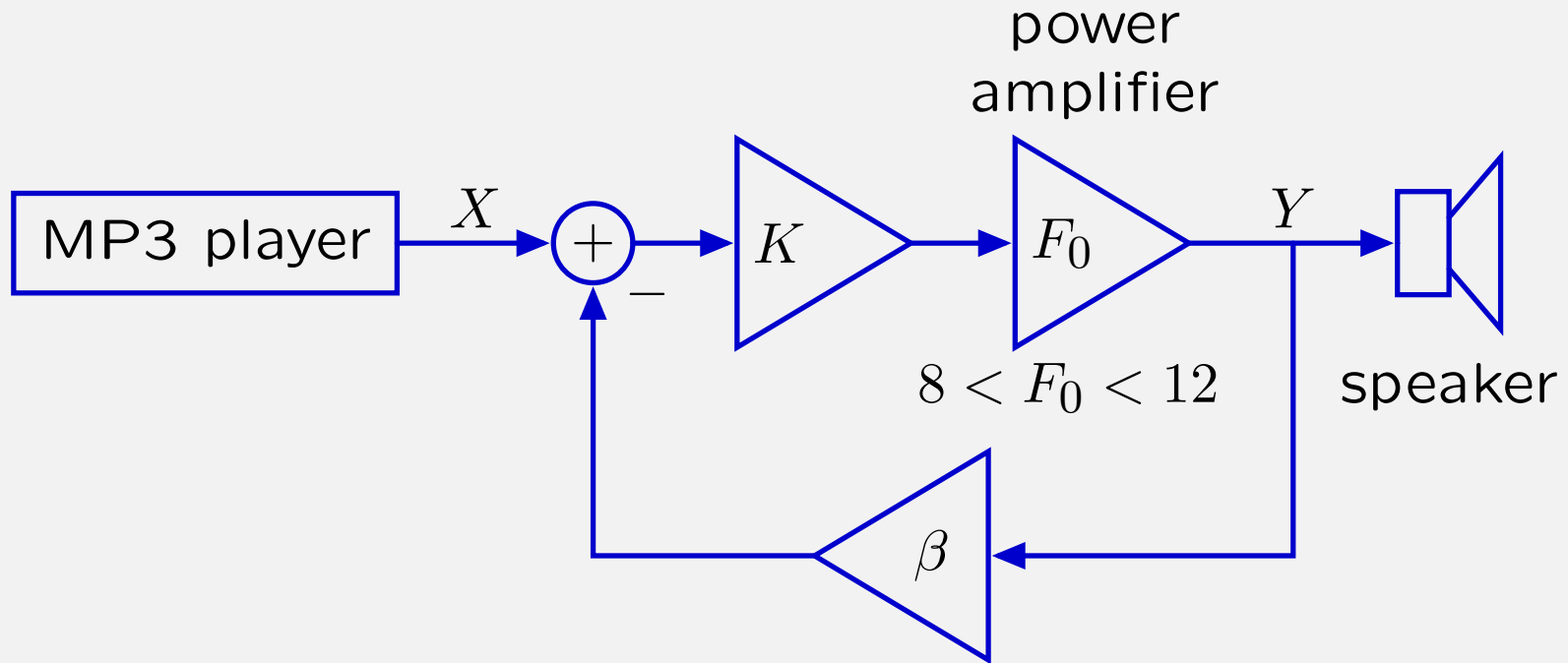

Feedback greatly reduces sensitivity to variations in K or F_0 .

$$\lim_{K \rightarrow \infty} H(s) = \frac{KF_0}{1 + \beta KF_0} \rightarrow \frac{1}{\beta}$$

What about variations in β ? Aren't those important?

Check Yourself

What about variations in β ? Aren't those important?

The value of β is typically determined with resistors, whose values are quite stable (compared to semiconductor devices).

Crossover Distortion

Feedback can compensate for parameter variation even when the variation occurs rapidly.

Example: using transistors to amplify power.

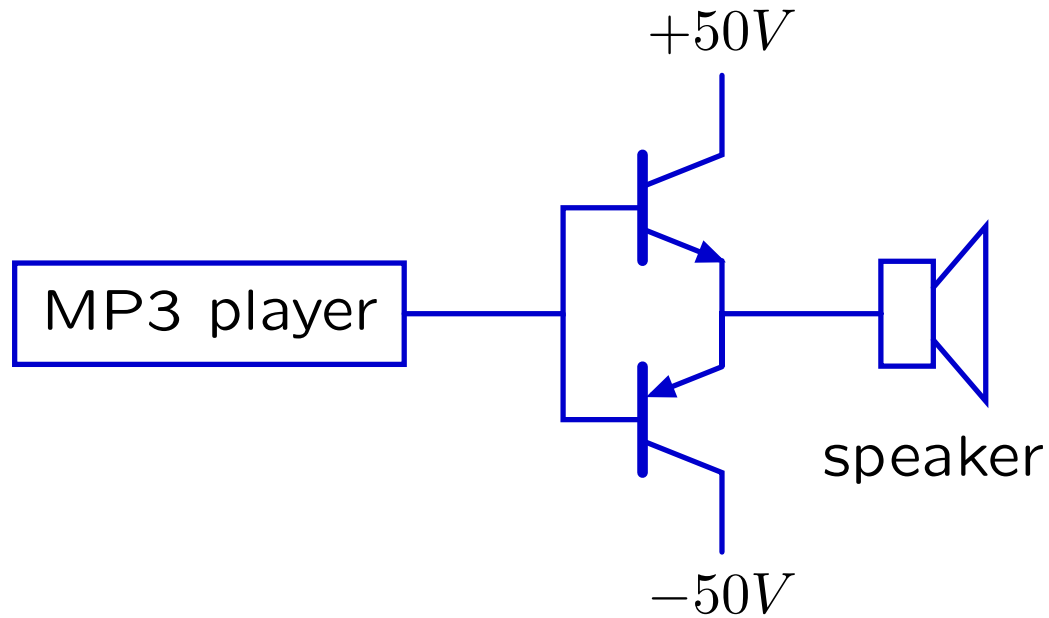

Crossover Distortion

This circuit introduces “crossover distortion.”

For the upper transistor to conduct, $V_i - V_o > V_T$.

For the lower transistor to conduct, $V_i - V_o < -V_T$.

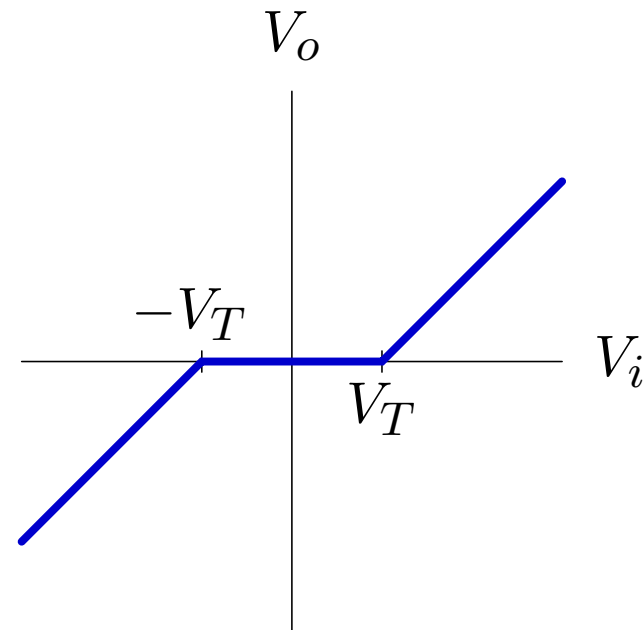
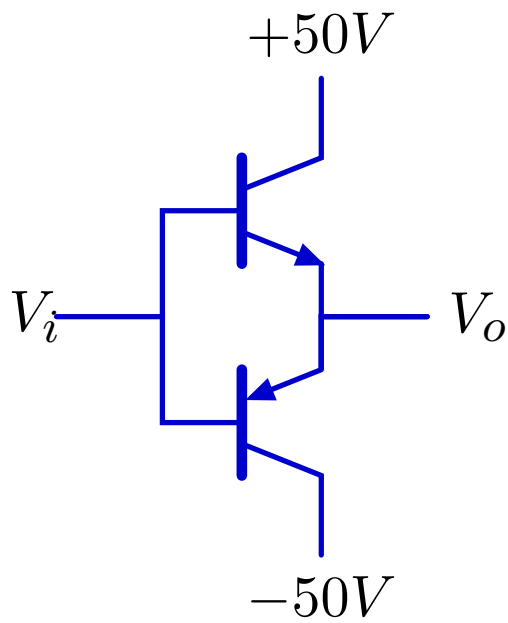

Crossover Distortion

Crossover distortion can have dramatic effects.

Example: crossover distortion when the input is $V_i(t) = B \sin(\omega_0 t)$.

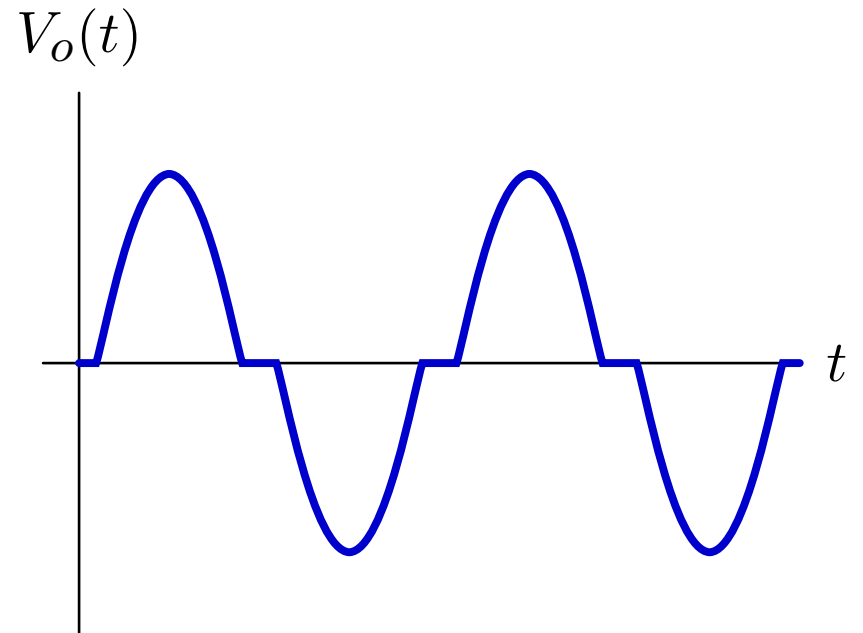
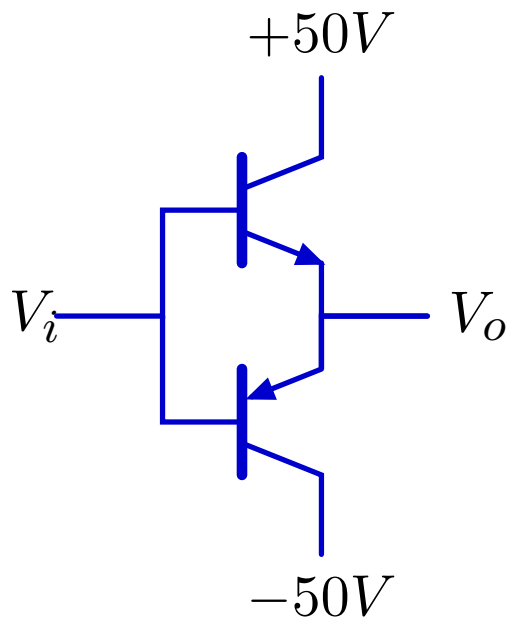

Crossover Distortion

Feedback can reduce the effects of crossover distortion.

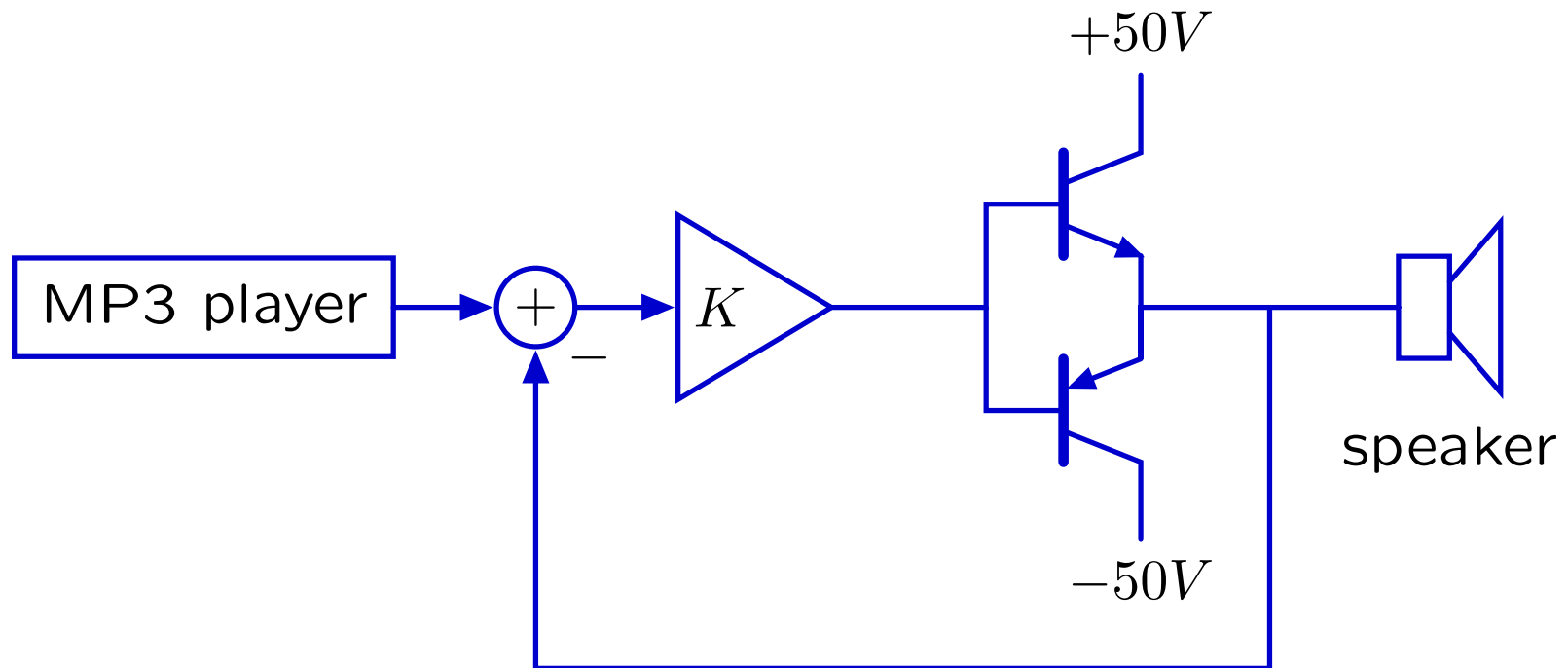

Crossover Distortion

When K is small, feedback has little effect on crossover distortion.

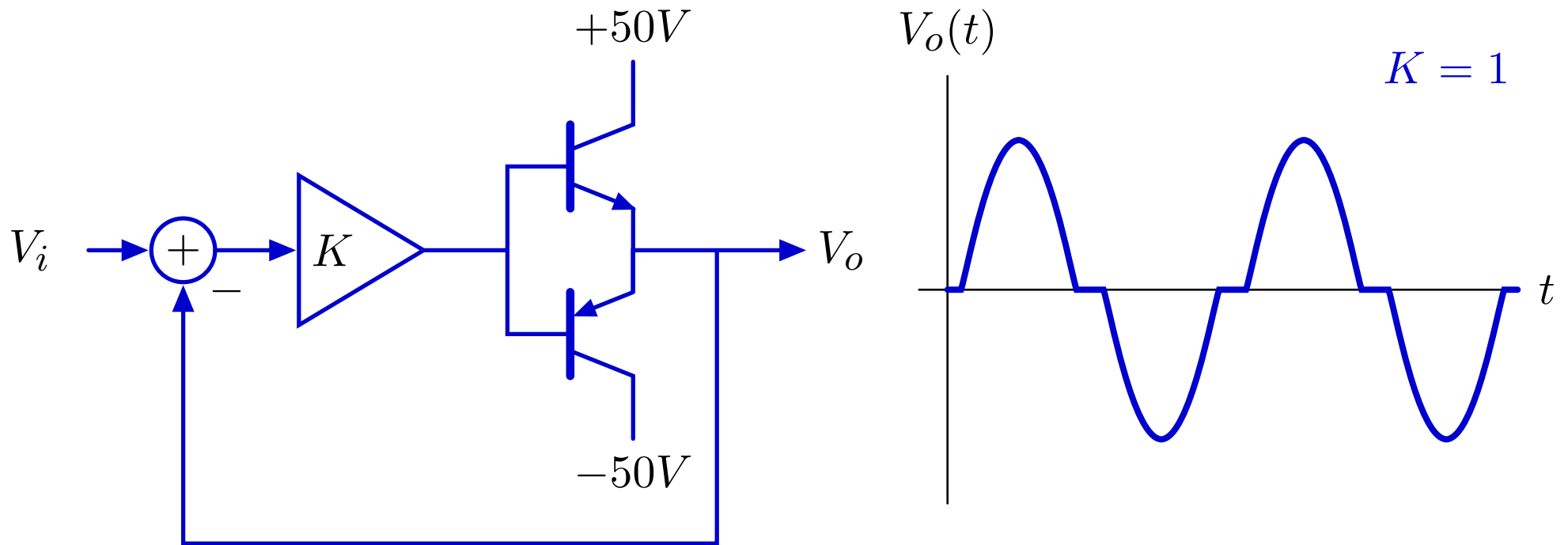

Crossover Distortion

As K increases, feedback reduces crossover distortion.

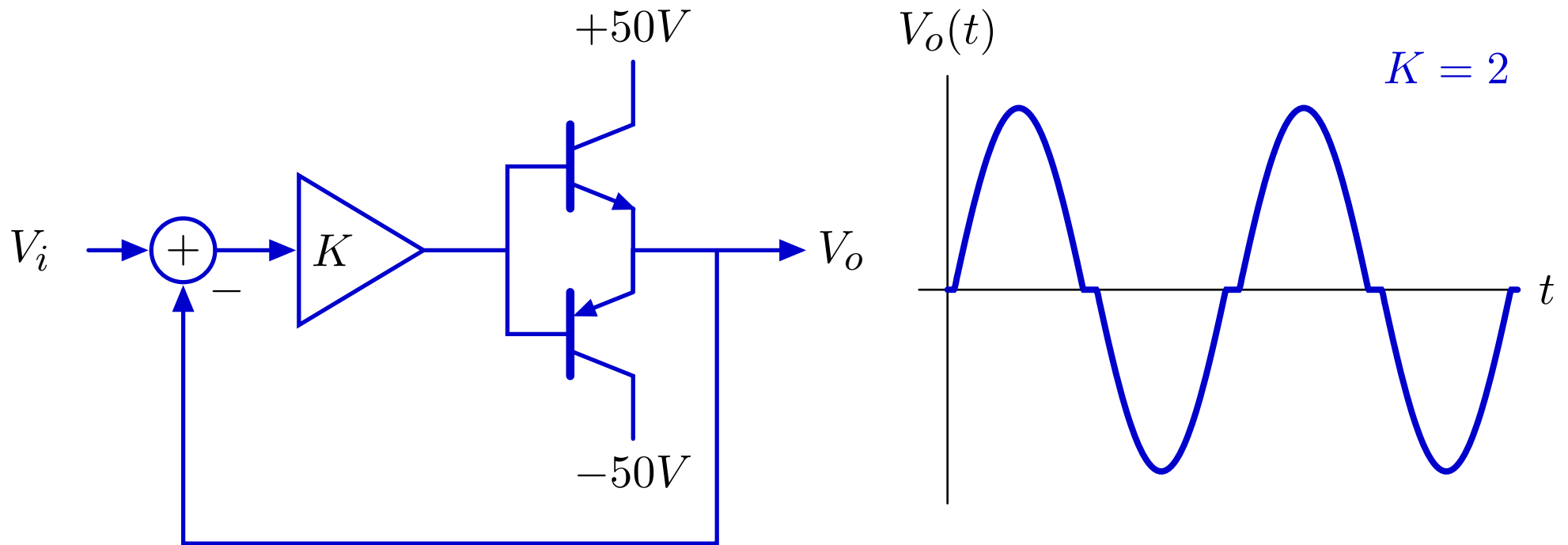

Crossover Distortion

As K increases, feedback reduces crossover distortion.

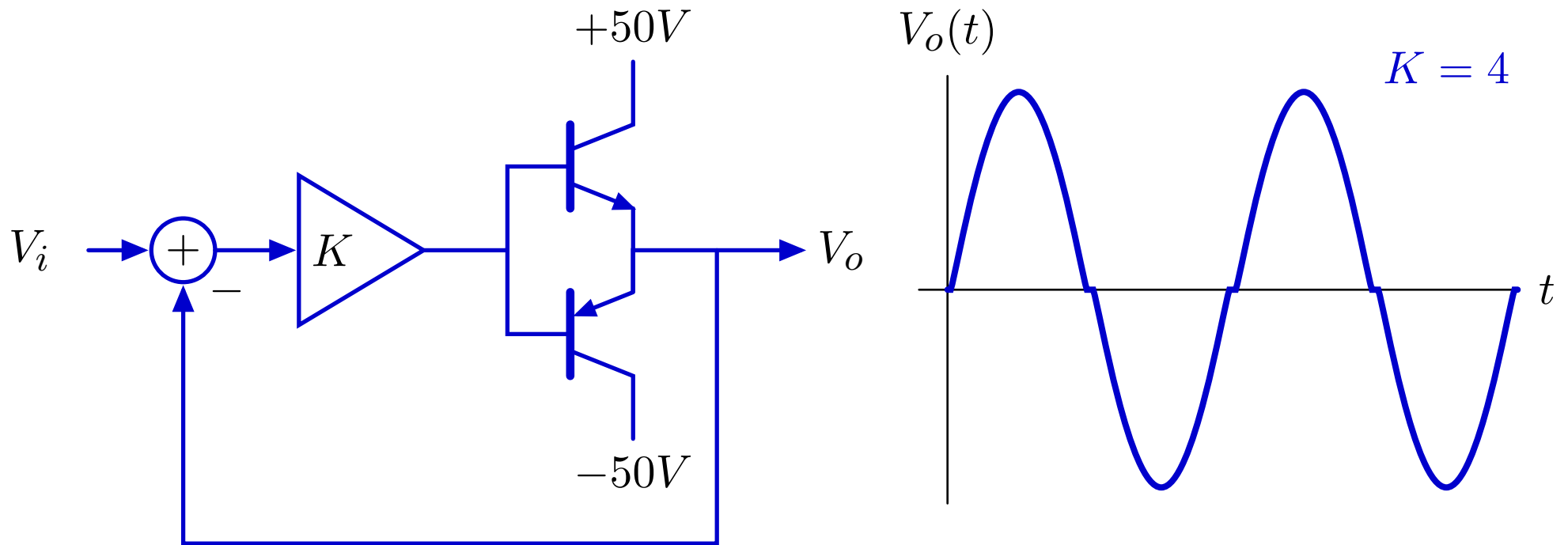

Crossover Distortion

As K increases, feedback reduces crossover distortion.

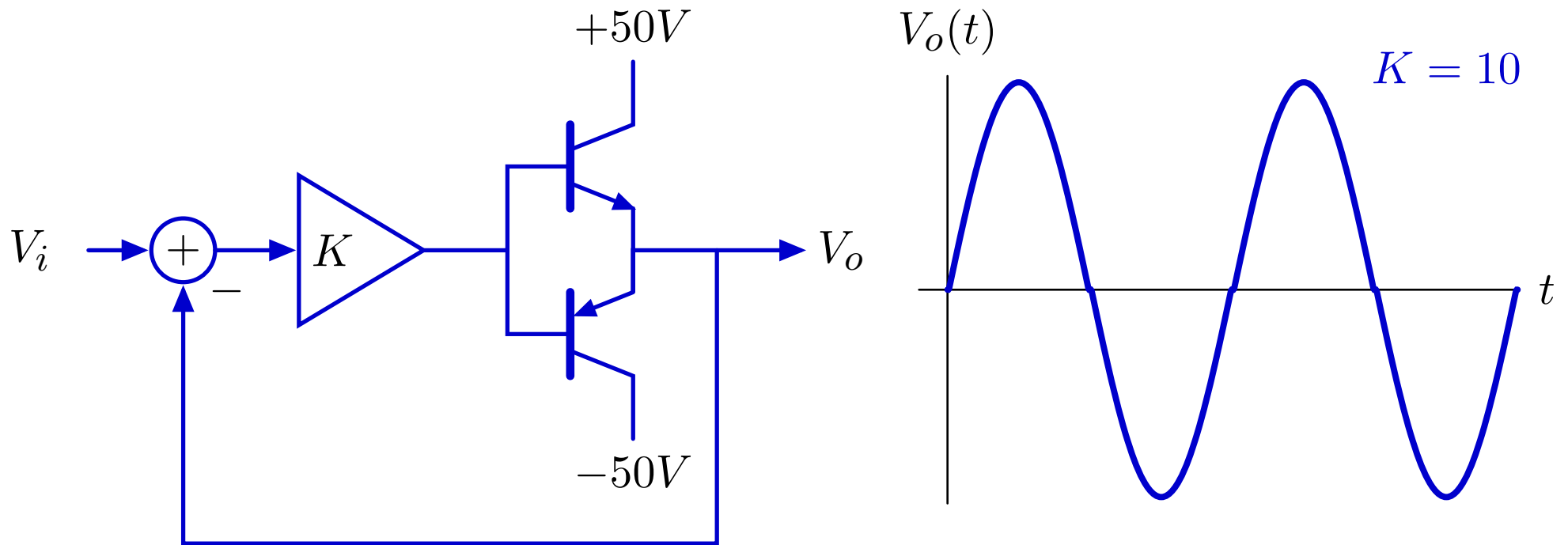

Crossover Distortion

Demo

- original
- no feedback
- $K = 2$
- $K = 4$
- $K = 8$
- $K = 16$
- original

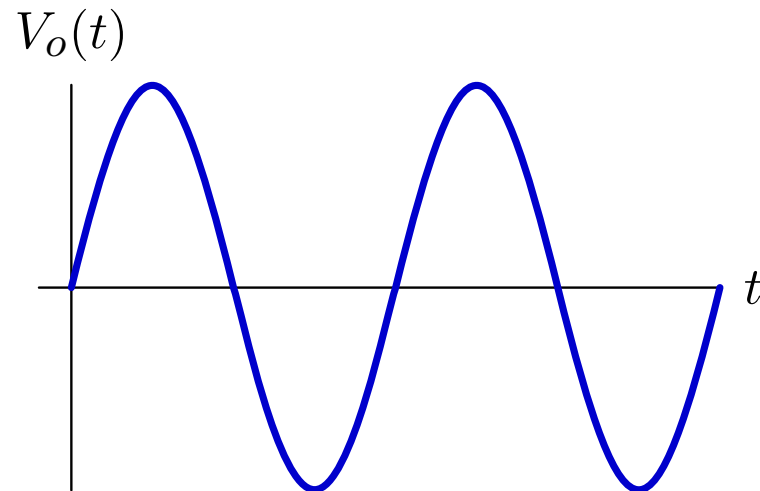
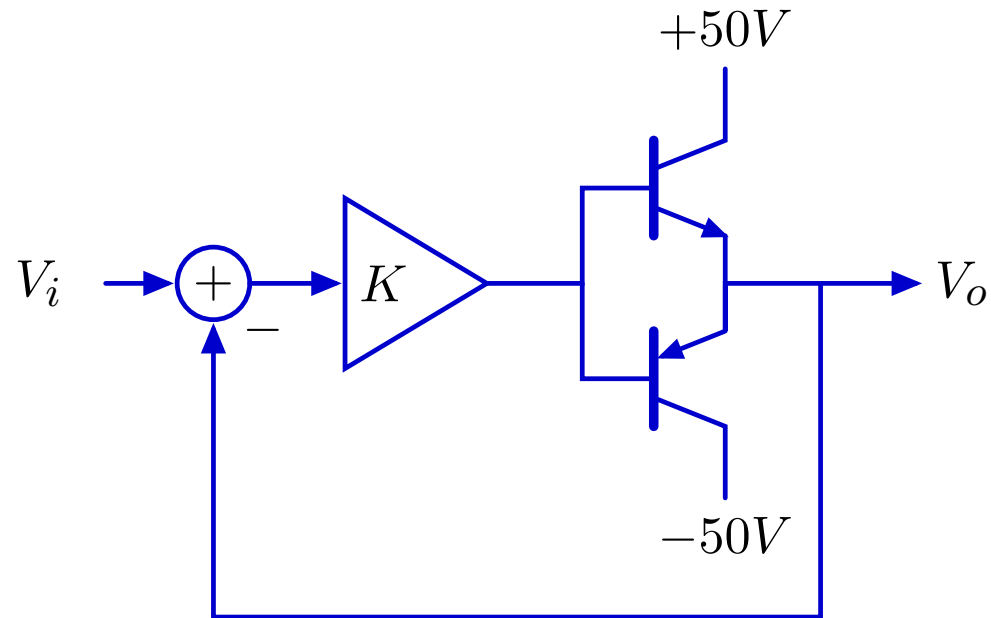

J.S. Bach, Sonata No. 1 in G minor Mvmt. IV. Presto
Nathan Milstein, violin

Feedback and Control

Using feedback to enhance performance.

Examples:

- improve performance of an op amp circuit.
- control position of a motor.
- reduce sensitivity to unwanted parameter variation.
- reduce distortions.
- stabilize unstable systems
 - magnetic levitation
 - inverted pendulum

Control of Unstable Systems

Feedback is useful for controlling **unstable** systems.

Example: Magnetic levitation.

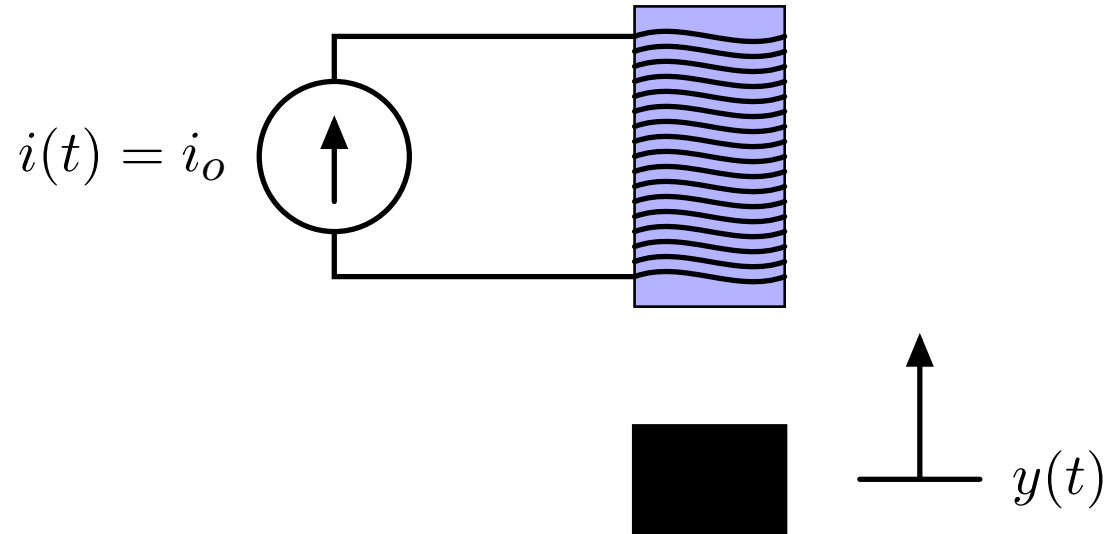

Control of Unstable Systems

Magnetic levitation is unstable.

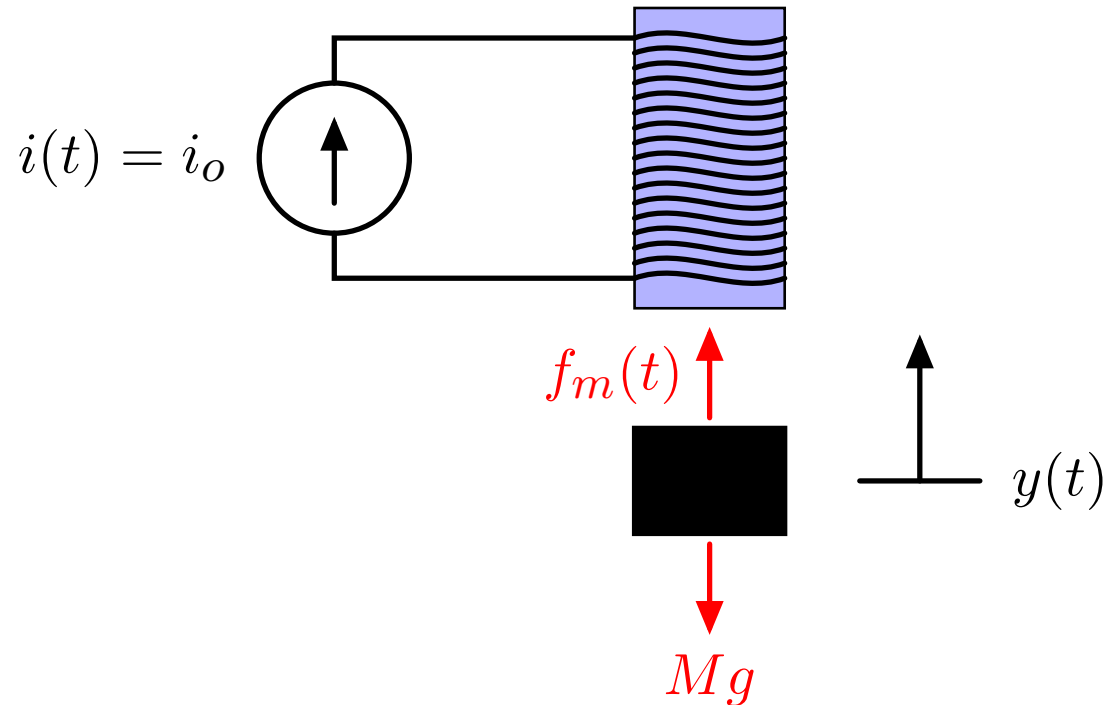

Equilibrium ($y = 0$): magnetic force $f_m(t)$ is equal to the weight Mg .

Increase $y \rightarrow$ increased force \rightarrow further increases y .

Decrease $y \rightarrow$ decreased force \rightarrow further decreases y .

Positive feedback!

Modeling Magnetic Levitation

The magnet generates a force that depends on the distance $y(t)$.

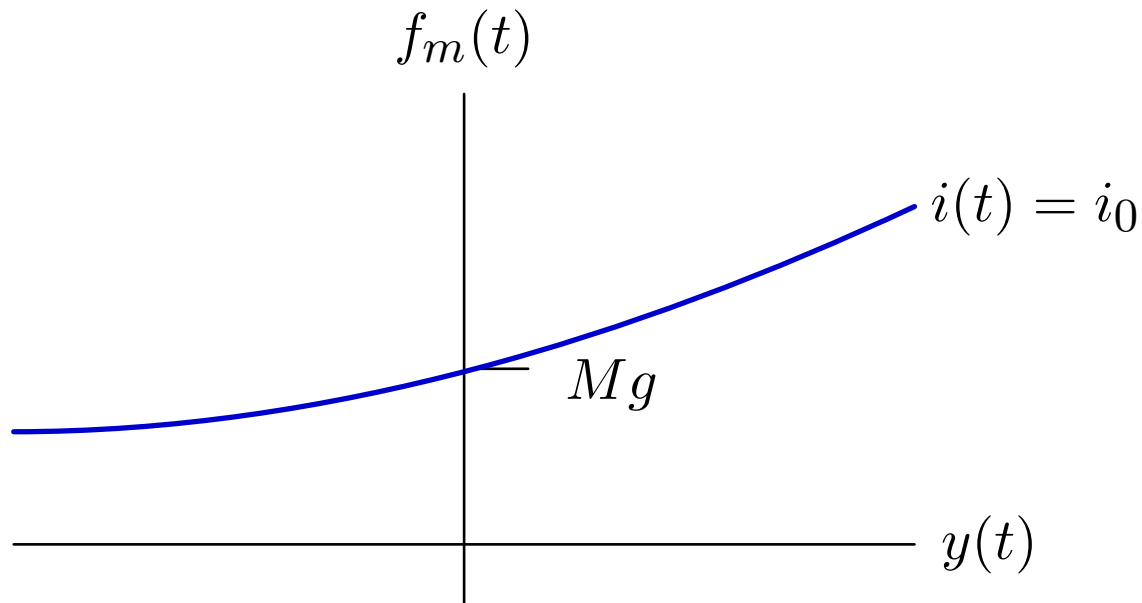
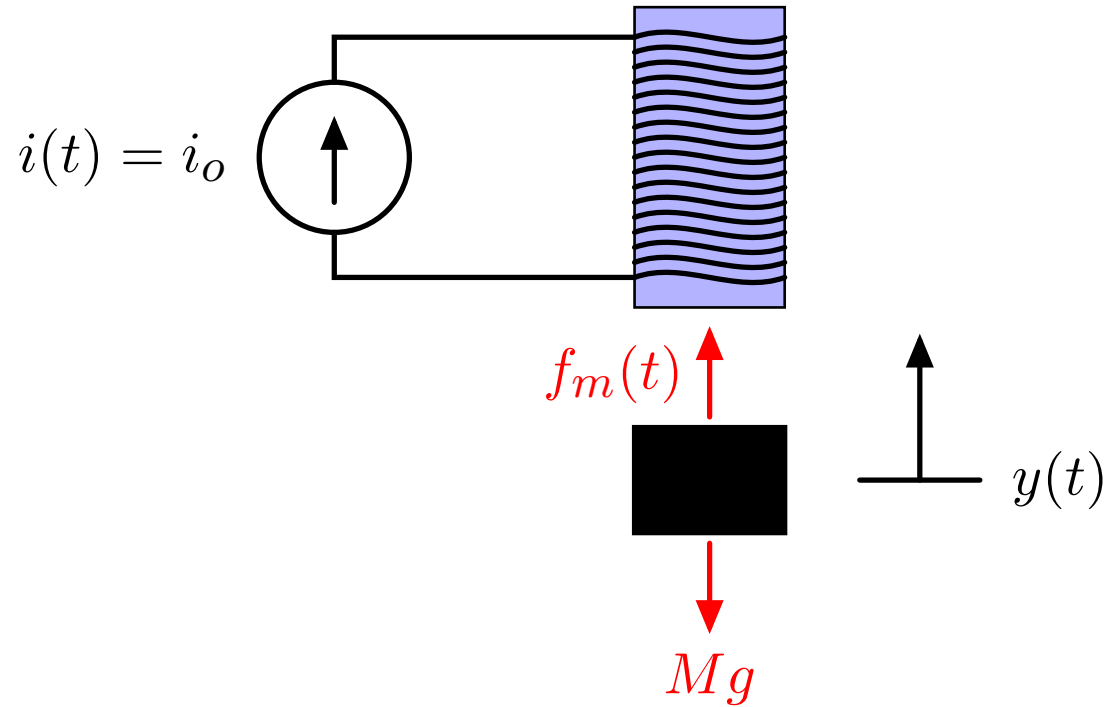

Modeling Magnetic Levitation

The net force accelerates the mass.

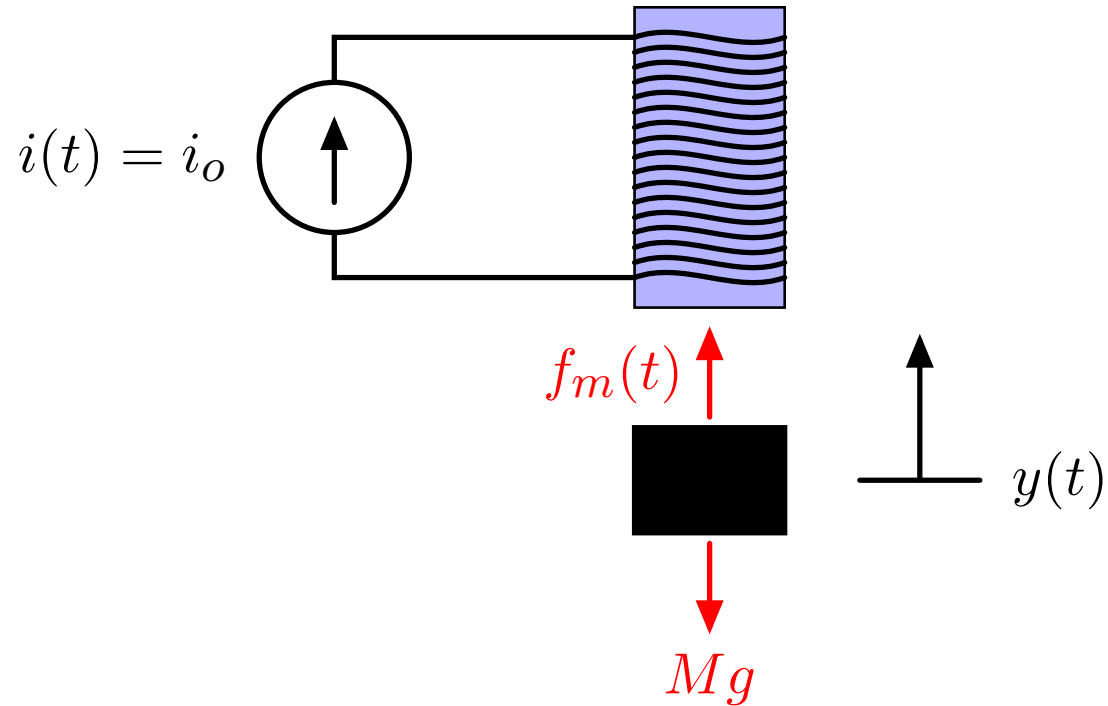

$$f_m(t) - Mg = f(t) = Ma = M\ddot{y}(t)$$

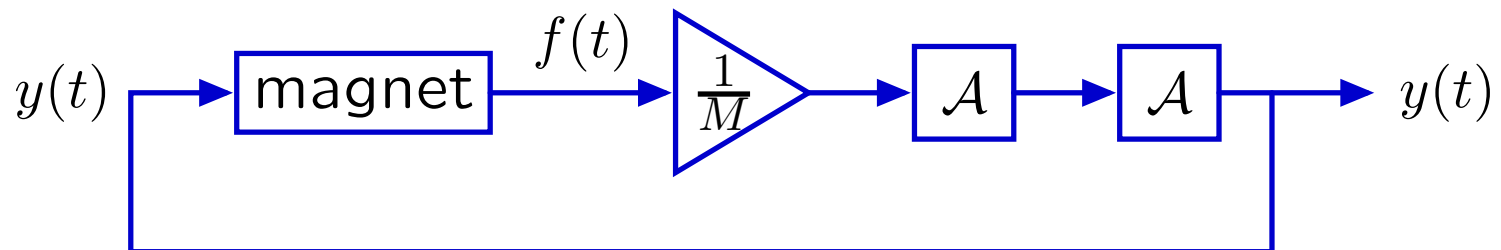

Modeling Magnetic Levitation

Over small distances, magnetic force grows \approx linearly with distance.

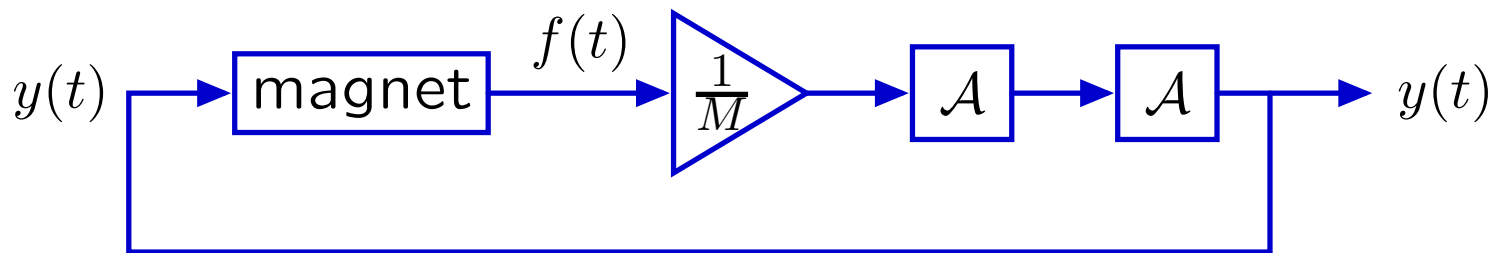
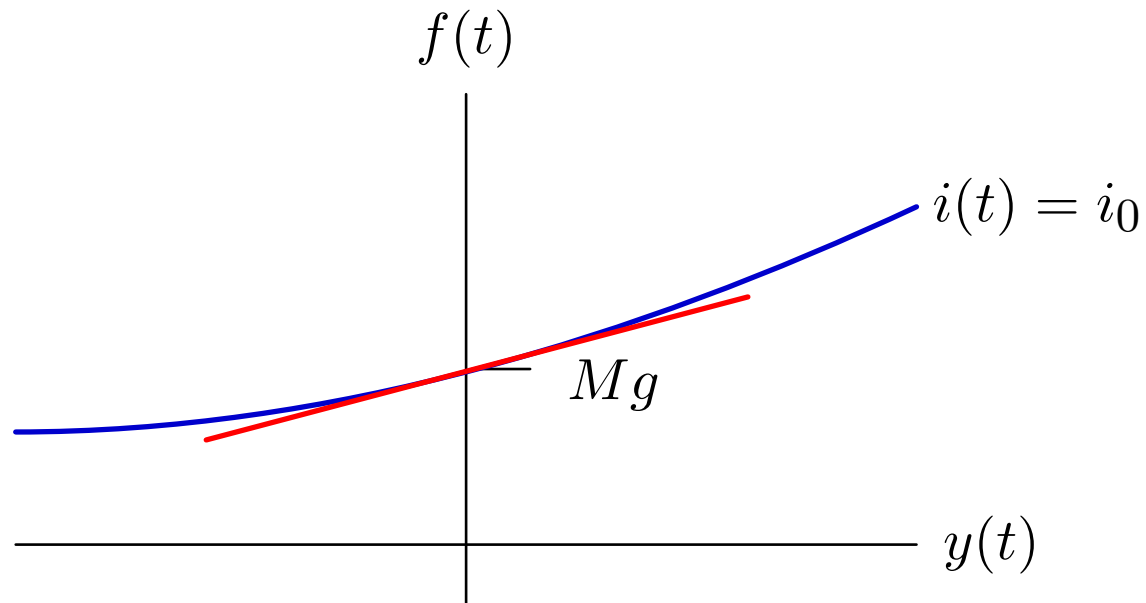

“Levitation” with a Spring

Relation between force and distance for a spring is opposite in sign.

$$F = K(x(t) - y(t)) = M\ddot{y}(t)$$

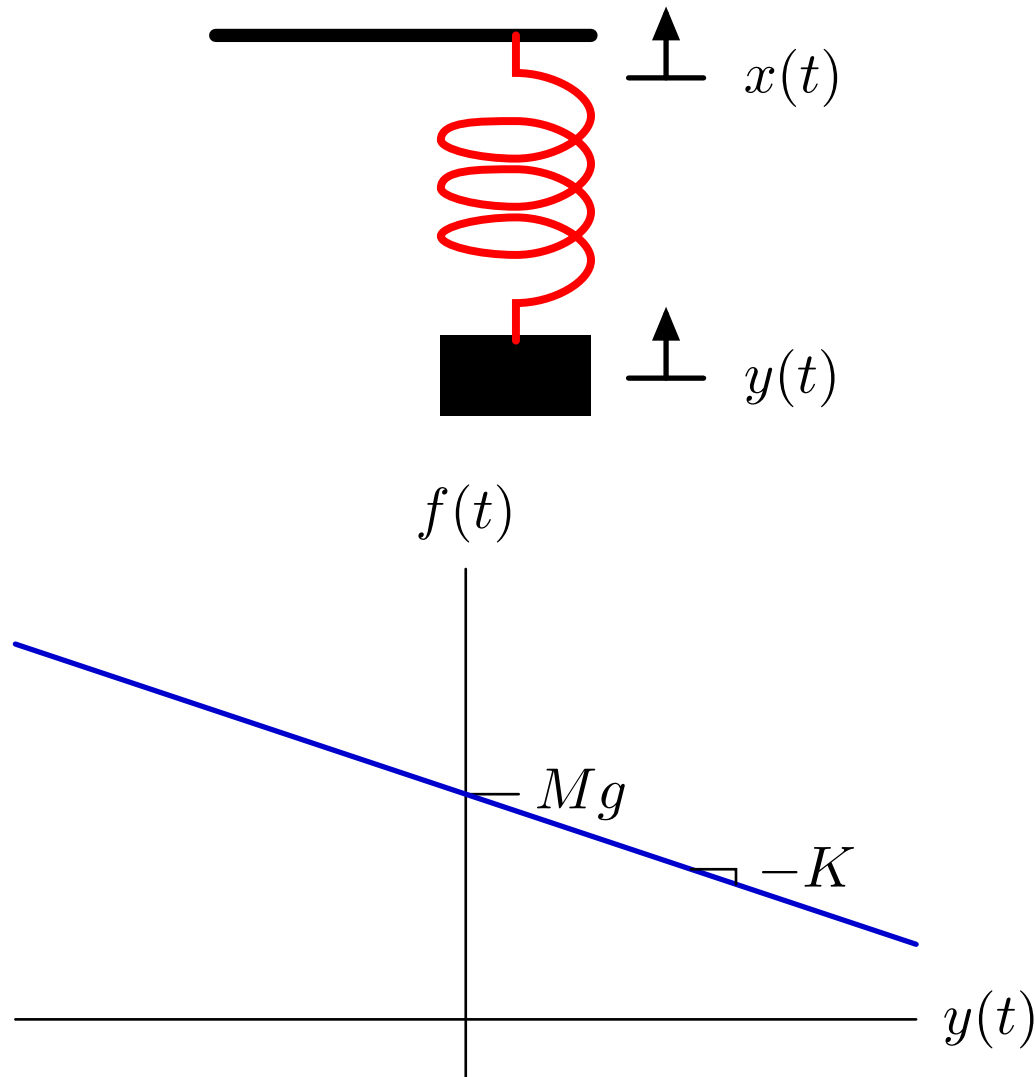

Modeling Magnetic Levitation

Over small distances, magnetic force nearly proportional to distance.

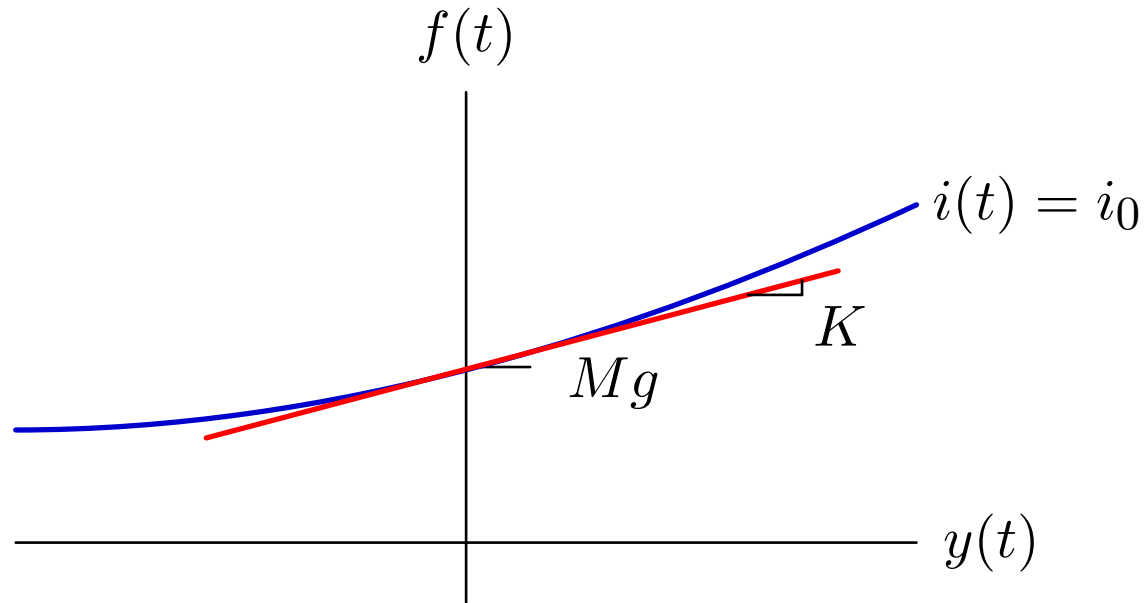

$$f(t) \approx Ky(t)$$

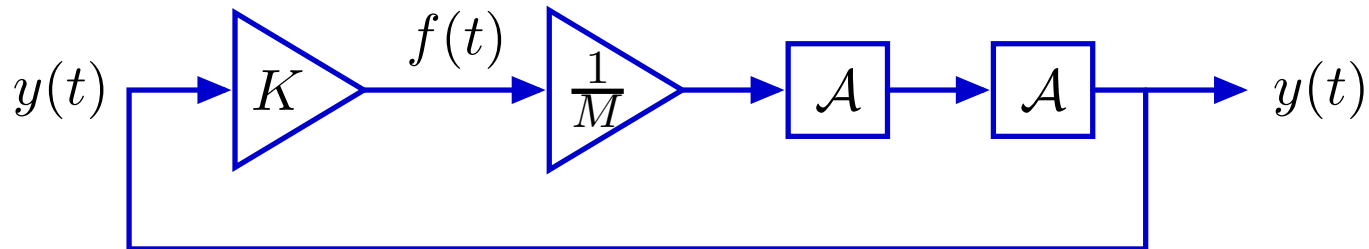

Block Diagrams

Block diagrams for magnetic levitation and spring/mass are similar.

Spring and mass

$$F = K(x(t) - y(t)) = M\ddot{y}(t)$$

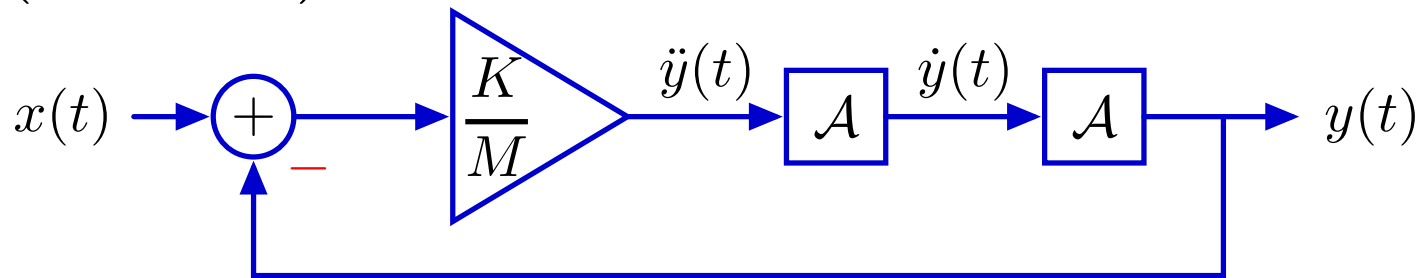

Magnetic levitation

$$F = Ky(t) = M\ddot{y}(t)$$

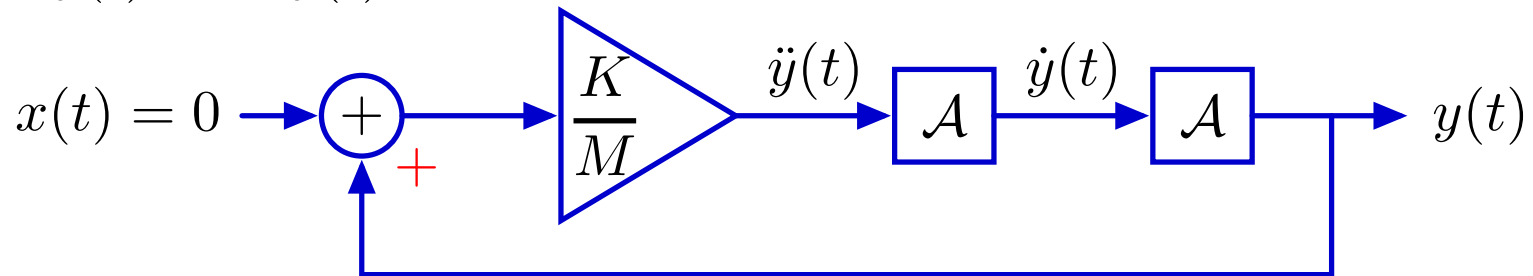

Check Yourself

How do the poles of these two systems differ?

Spring and mass

$$F = K(x(t) - y(t)) = M\ddot{y}(t)$$

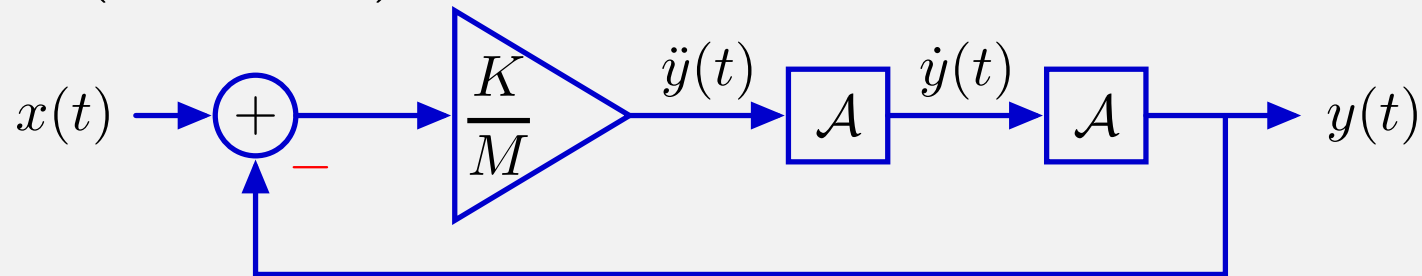

Magnetic levitation

$$F = Ky(t) = M\ddot{y}(t)$$

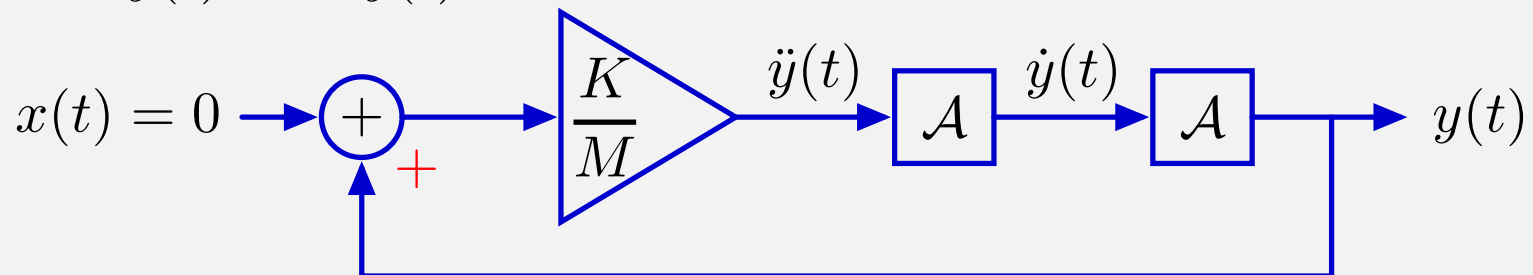

Check Yourself

How do the poles of the two systems differ?

Spring and mass

$$F = K(x(t) - y(t)) = M\ddot{y}(t)$$

$$\frac{Y}{X} = \frac{\frac{K}{M}}{s^2 + \frac{K}{M}} \rightarrow s = \pm j\sqrt{\frac{K}{M}}$$

s-plane

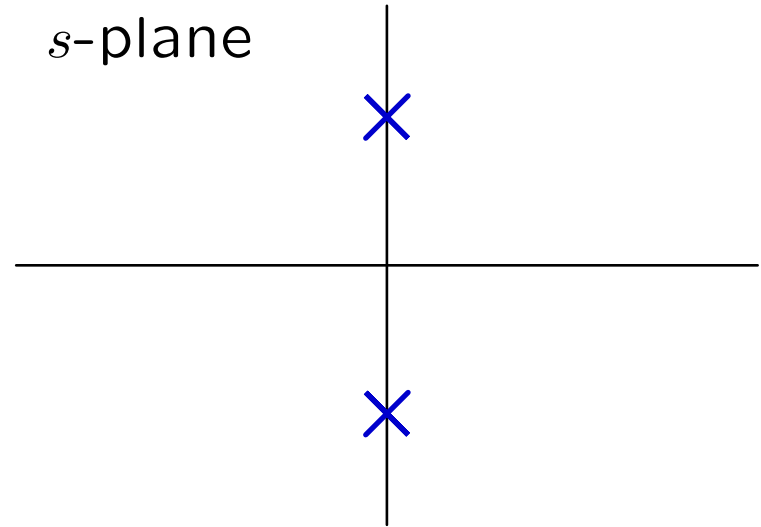

Magnetic levitation

$$F = Ky(t) = M\ddot{y}(t)$$

$$s^2 = \frac{K}{M} \rightarrow s = \pm\sqrt{\frac{K}{M}}$$

s-plane

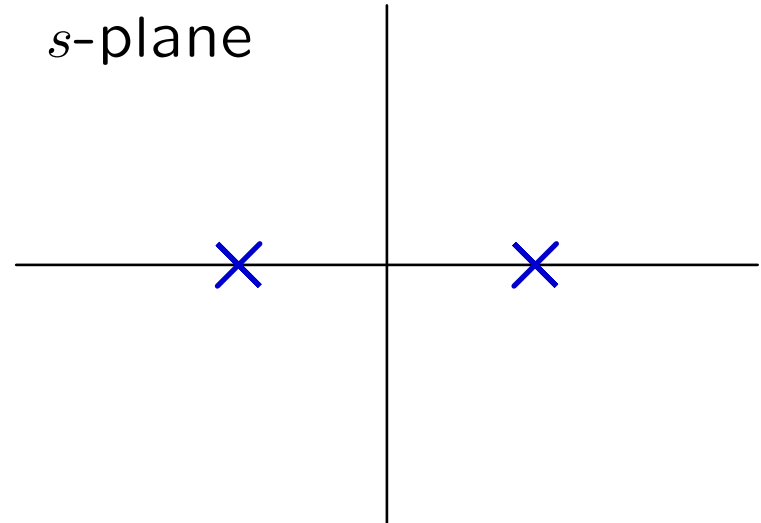

Magnetic Levitation is Unstable

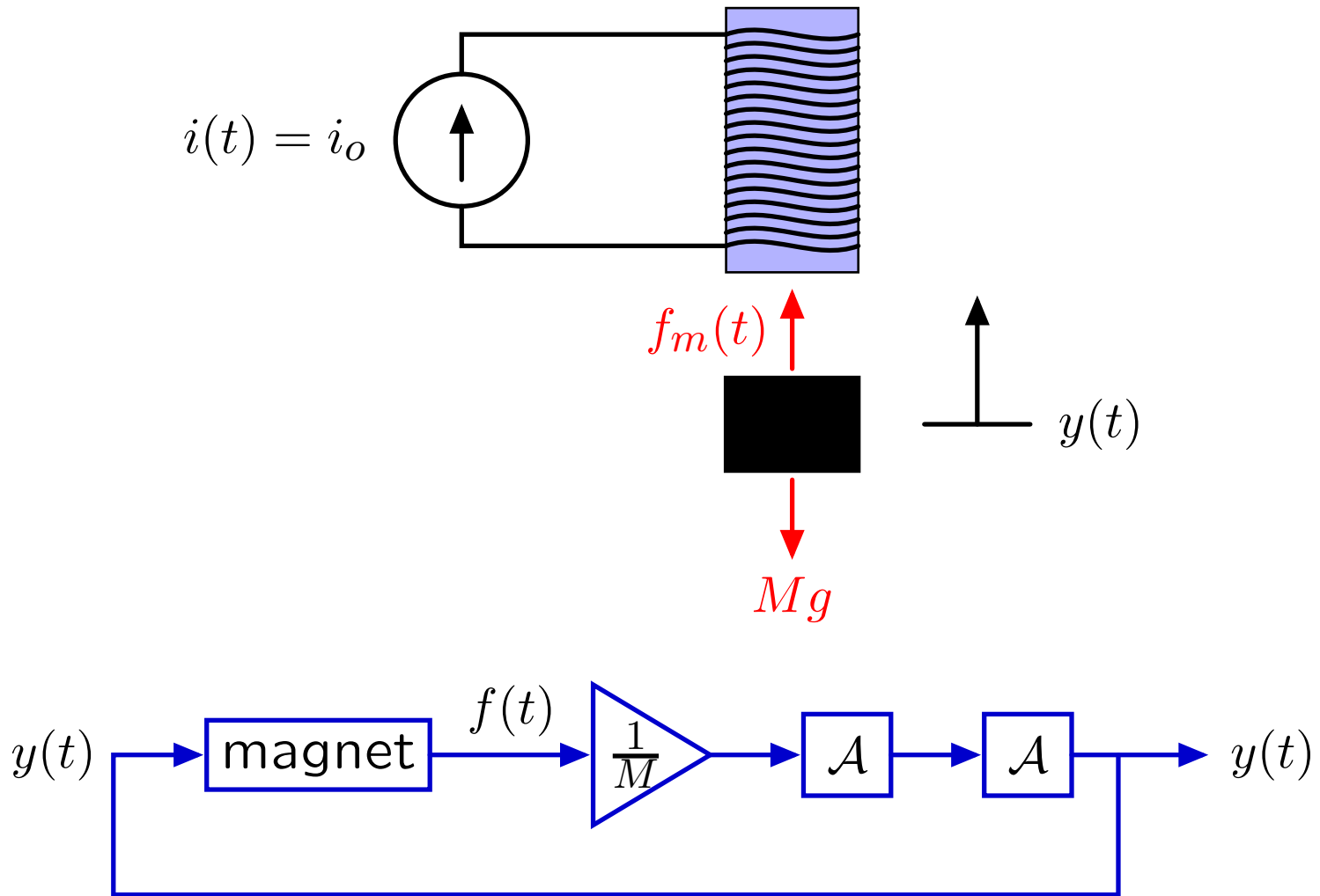

Magnetic Levitation

We can stabilize this system by adding an additional feedback loop to control $i(t)$.

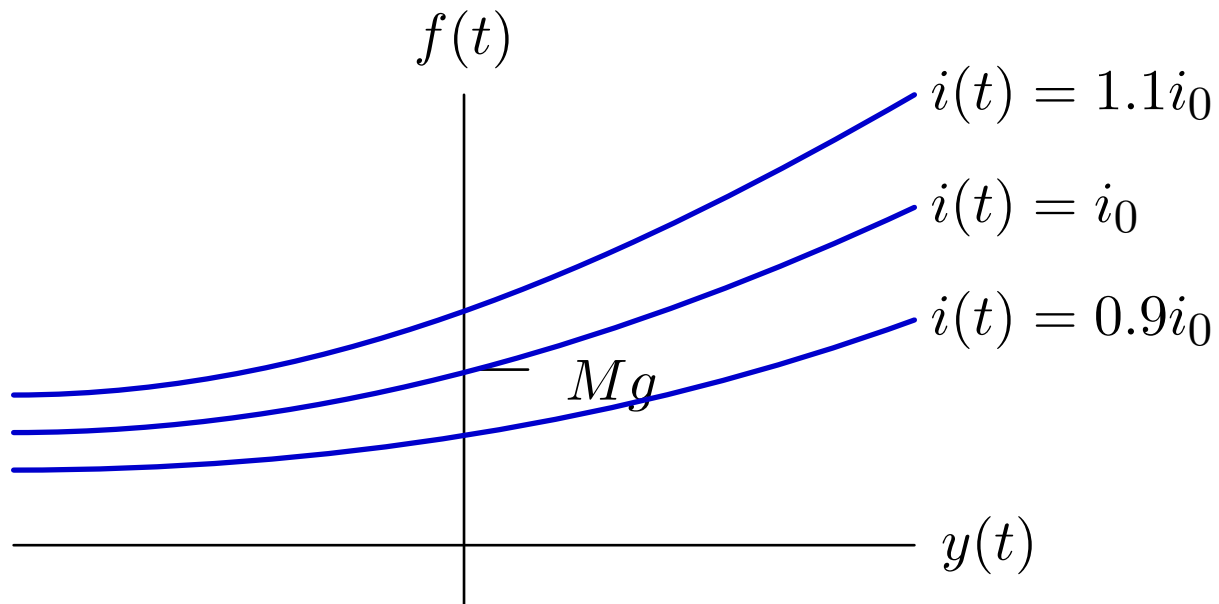

Stabilizing Magnetic Levitation

Stabilize magnetic levitation by controlling the magnet current.

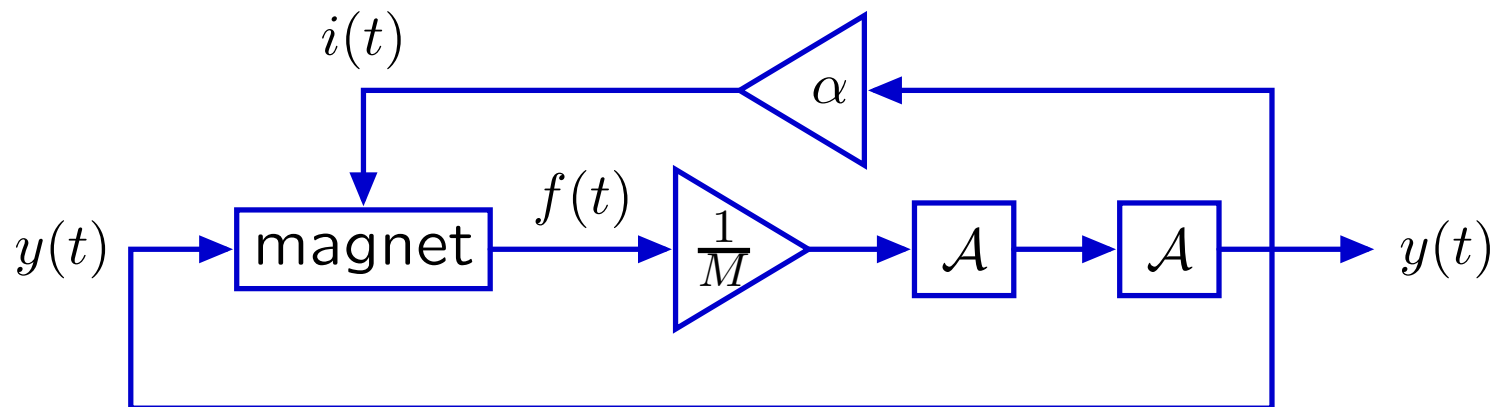
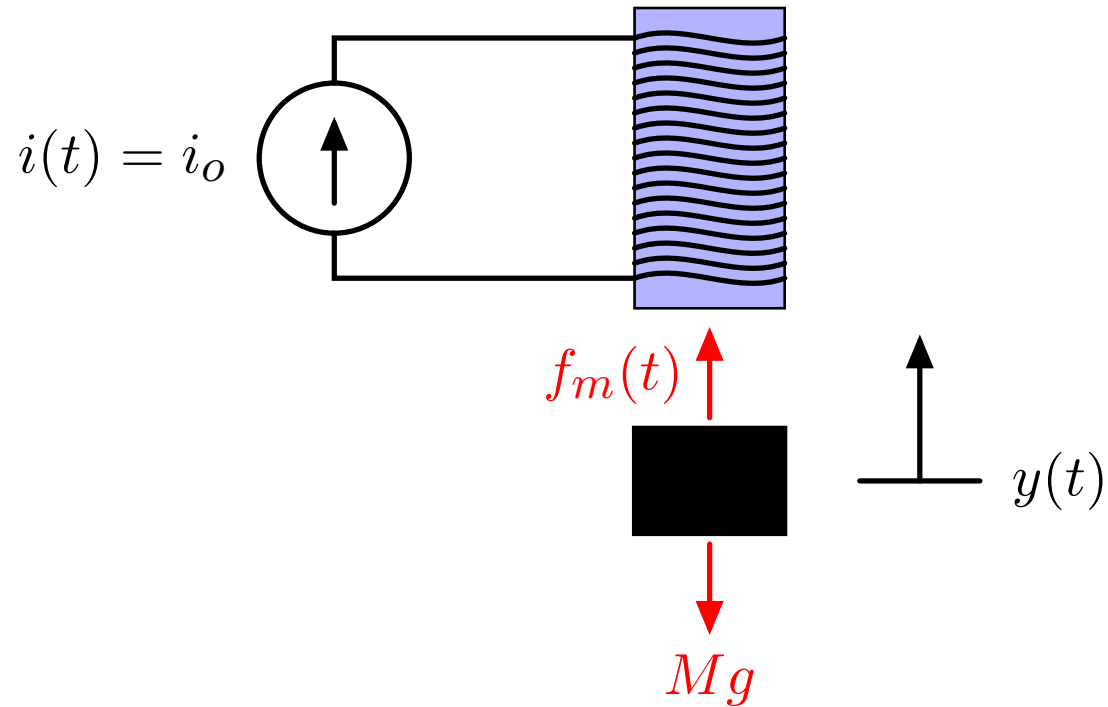

Stabilizing Magnetic Levitation

Stabilize magnetic levitation by controlling the magnet current.

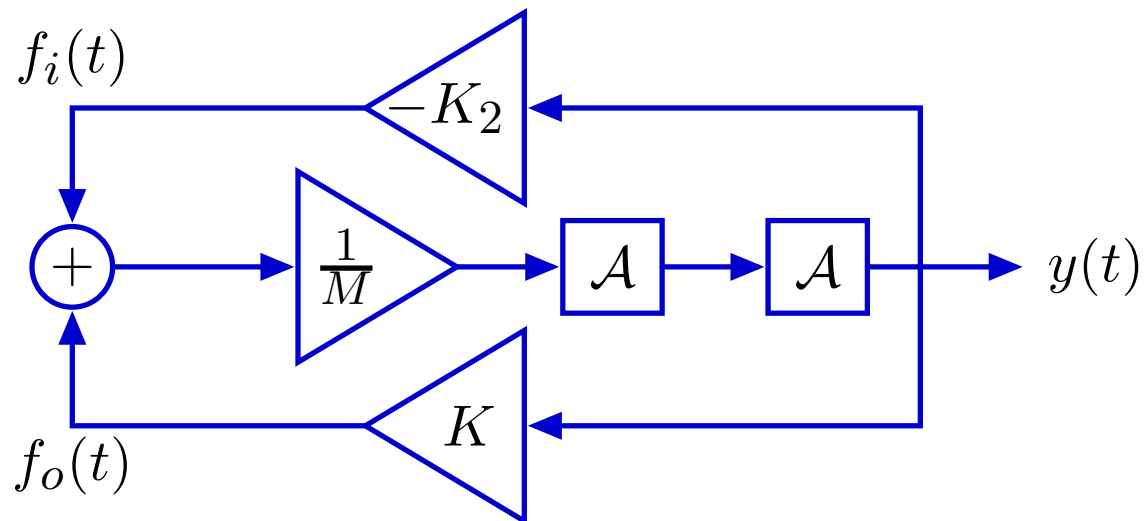
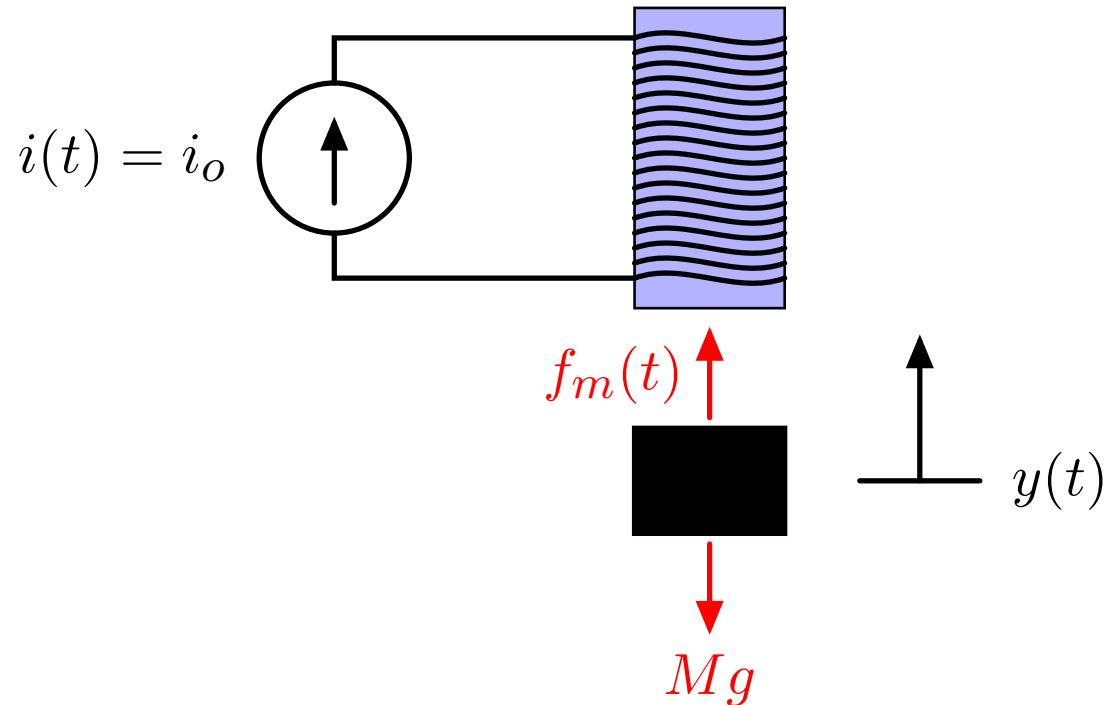

Magnetic Levitation

Increasing K_2 moves poles toward the origin and then onto $j\omega$ axis.

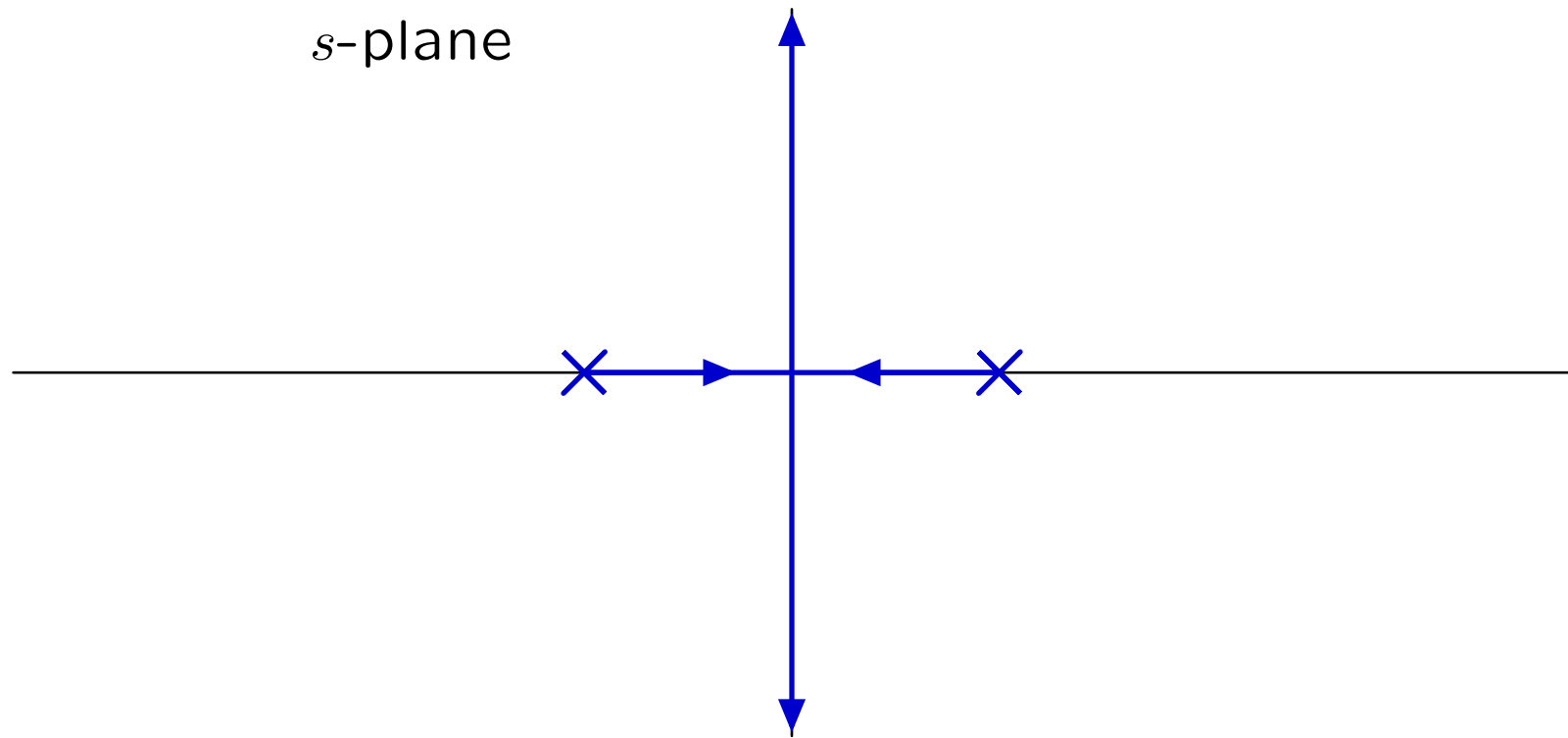
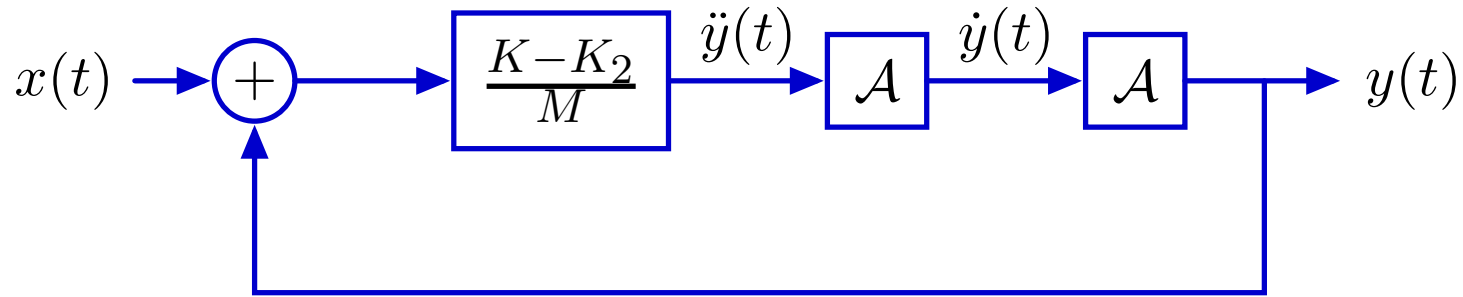

But the poles are still marginally stable.

Magnetic Levitation

Adding a zero makes the poles stable for sufficiently large K_2 .

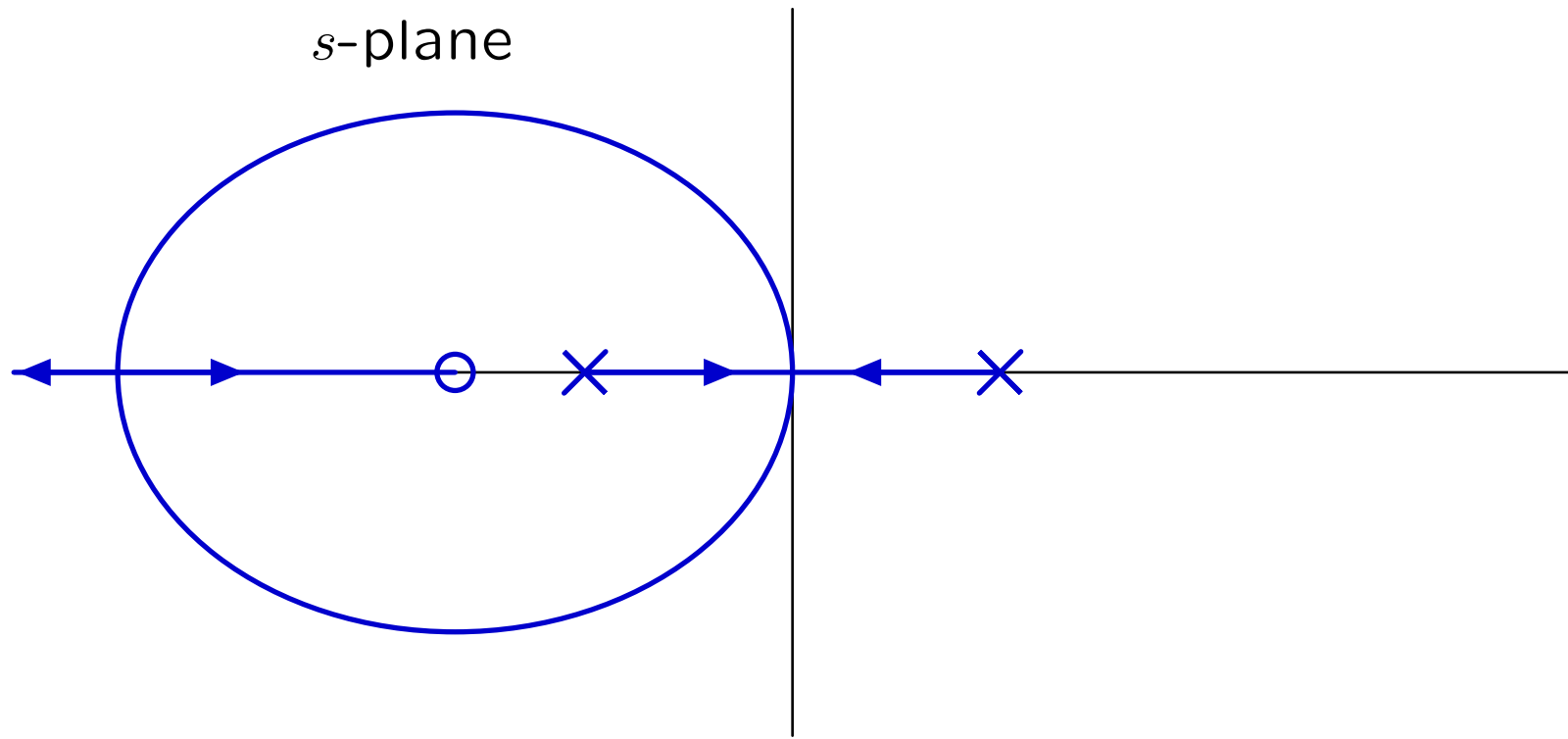
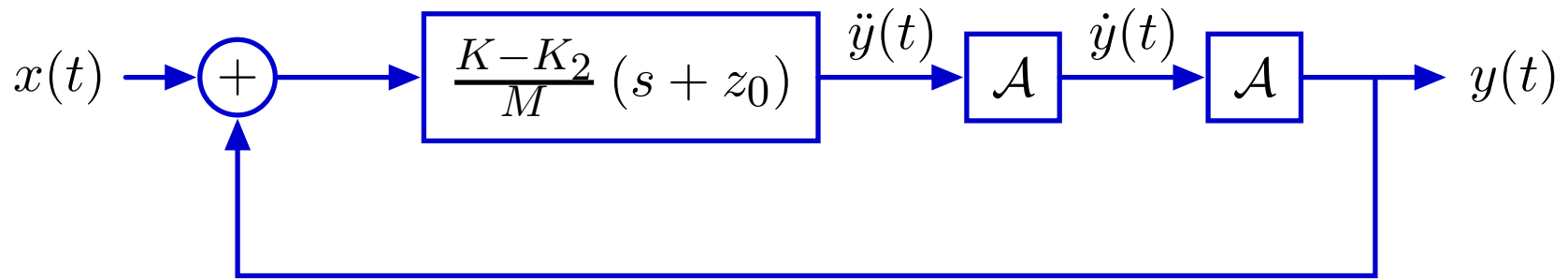

Try it: Demo [designed by Prof. James Roberge].

Inverted Pendulum

As a final example of stabilizing an unstable system, consider an inverted pendulum.

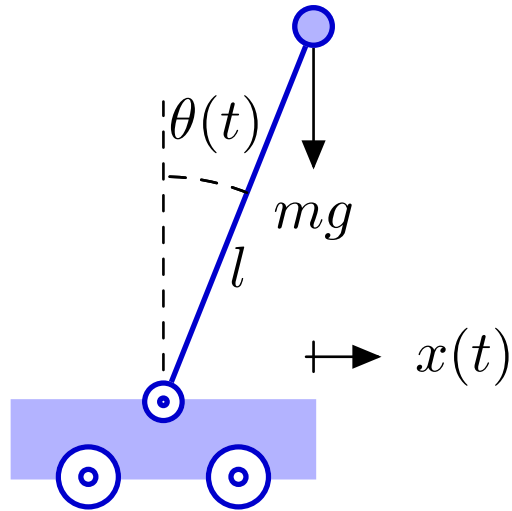

lab frame
(inertial)

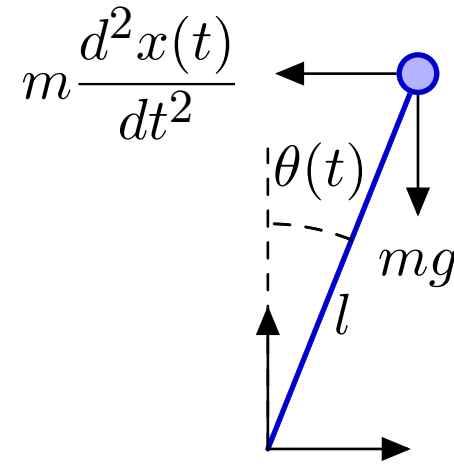

cart frame
(non-inertial)

$$\underbrace{ml^2}_{I} \frac{d^2\theta(t)}{dt^2} = \underbrace{mg}_{\text{force}} \underbrace{l \sin \theta(t)}_{\text{distance}} - \underbrace{m \frac{d^2x(t)}{dt^2}}_{\text{force}} \underbrace{l \cos \theta(t)}_{\text{distance}}$$

Check Yourself: Inverted Pendulum

Where are the poles of this system?

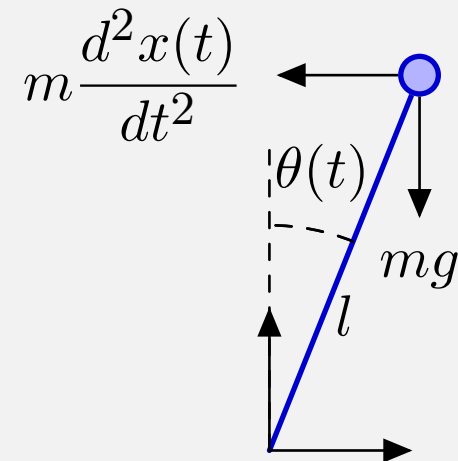
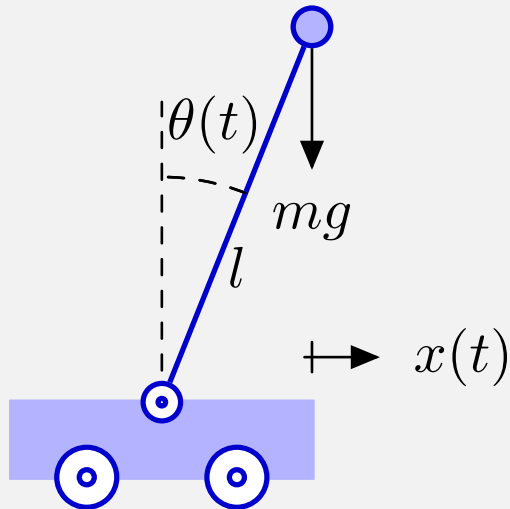

$$ml^2 \frac{d^2 \theta(t)}{dt^2} = mgl \sin \theta(t) - m \frac{d^2 x(t)}{dt^2} l \cos \theta(t)$$

Check Yourself: Inverted Pendulum

Where are the poles of this system?

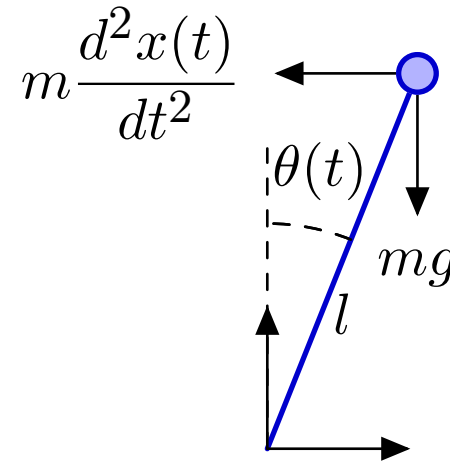
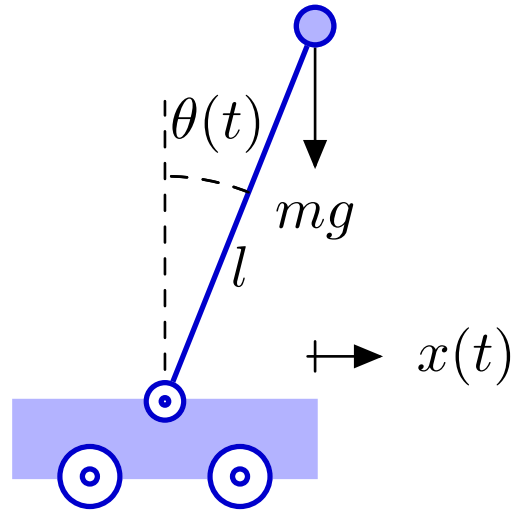

$$ml^2 \frac{d^2 \theta(t)}{dt^2} = mgl \sin \theta(t) - m \frac{d^2 x(t)}{dt^2} l \cos \theta(t)$$

$$ml^2 \frac{d^2 \theta(t)}{dt^2} - mgl \theta(t) = -ml \frac{d^2 x(t)}{dt^2}$$

$$H(s) = \frac{\Theta}{X} = \frac{-mls^2}{ml^2 s^2 - mgl} = \frac{-s^2/l}{s^2 - g/l}$$

$$\text{poles at } s = \pm \sqrt{\frac{g}{l}}$$

Inverted Pendulum

This unstable system can be stabilized with feedback.

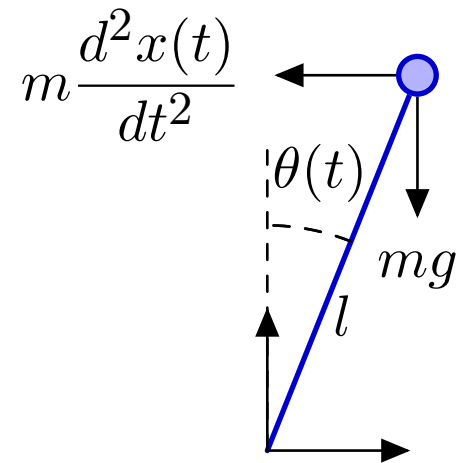
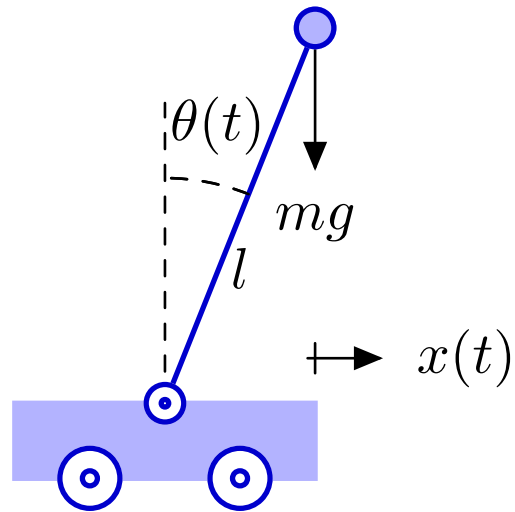

Try it. Demo. [originally designed by Marcel Gaudreau]

Feedback and Control

Using feedback to enhance performance.

Examples:

- improve performance of an op amp circuit.
- control position of a motor.
- reduce sensitivity to unwanted parameter variation.
- reduce distortions.
- stabilize unstable systems
 - magnetic levitation
 - inverted pendulum

MIT OpenCourseWare
<http://ocw.mit.edu>

6.003 Signals and Systems
Spring 2010

For information about citing these materials or our Terms of Use, visit: <http://ocw.mit.edu/terms>.