

# 6.003: Signals and Systems

## CT Fourier Transform

*April 8, 2010*

# CT Fourier Transform

---

Representing signals by their frequency content.

$$X(j\omega) = \int_{-\infty}^{\infty} x(t)e^{-j\omega t} dt \quad (\text{"analysis" equation})$$

$$x(t) = \frac{1}{2\pi} \int_{-\infty}^{\infty} X(j\omega)e^{j\omega t} d\omega \quad (\text{"synthesis" equation})$$

- generalizes Fourier series to represent aperiodic signals.
- equals Laplace transform  $X(s)|_{s=j\omega}$  if ROC includes  $j\omega$  axis.  
→ inherits properties of Laplace transform.
- complex-valued function of **real** domain  $\omega$ .
- simple "inverse" relation  
→ more general than table-lookup method for inverse Laplace.  
→ "duality."
- **filtering.**
- **applications in physics.**

# Filtering

---

Notion of a filter.

LTI systems

- cannot create new frequencies.
- can only scale magnitudes and shift phases of existing components.

Example: Low-Pass Filtering with an RC circuit

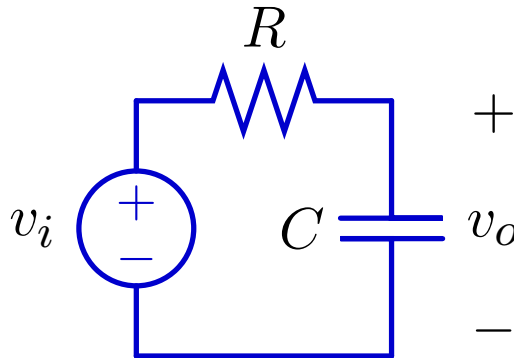

# Lowpass Filter

Calculate the frequency response of an RC circuit.

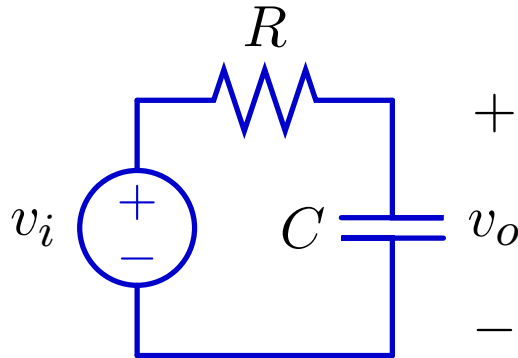

$$\text{KVL: } v_i(t) = Ri(t) + v_o(t)$$

$$\text{C: } i(t) = C\dot{v}_o(t)$$

$$\text{Solving: } v_i(t) = RC\dot{v}_o(t) + v_o(t)$$

$$V_i(s) = (1 + sRC)V_o(s)$$

$$H(s) = \frac{V_o(s)}{V_i(s)} = \frac{1}{1 + sRC}$$

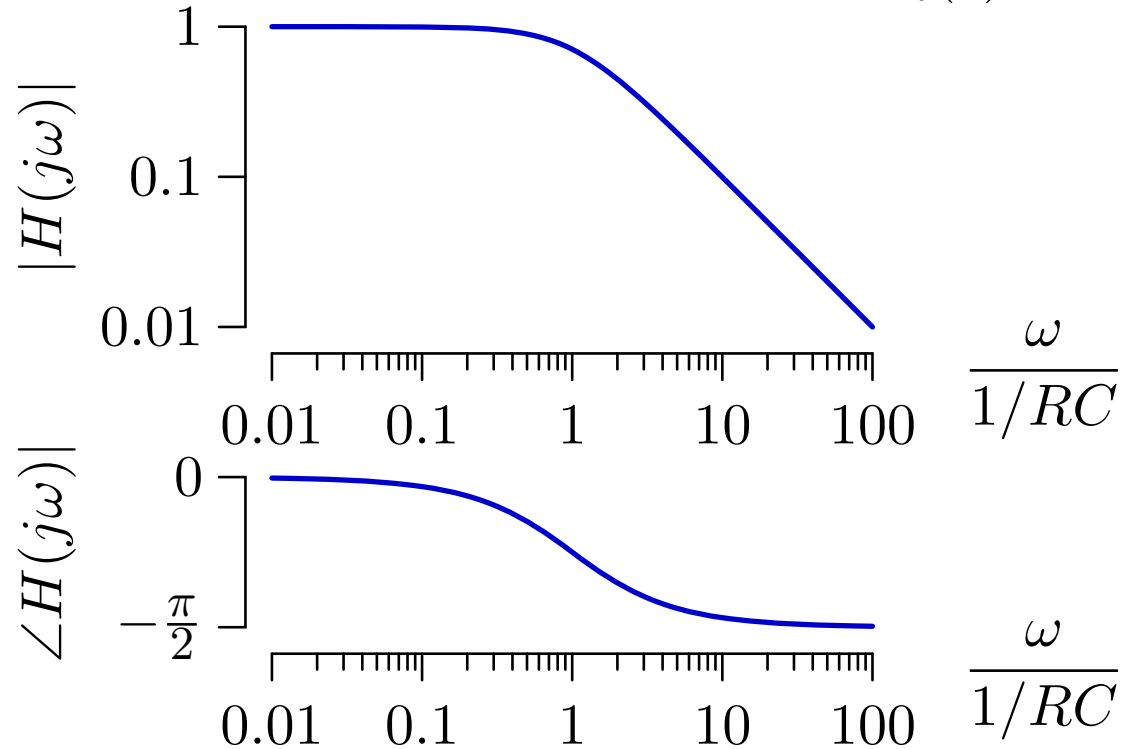

# Lowpass Filtering

Let the input be a square wave.

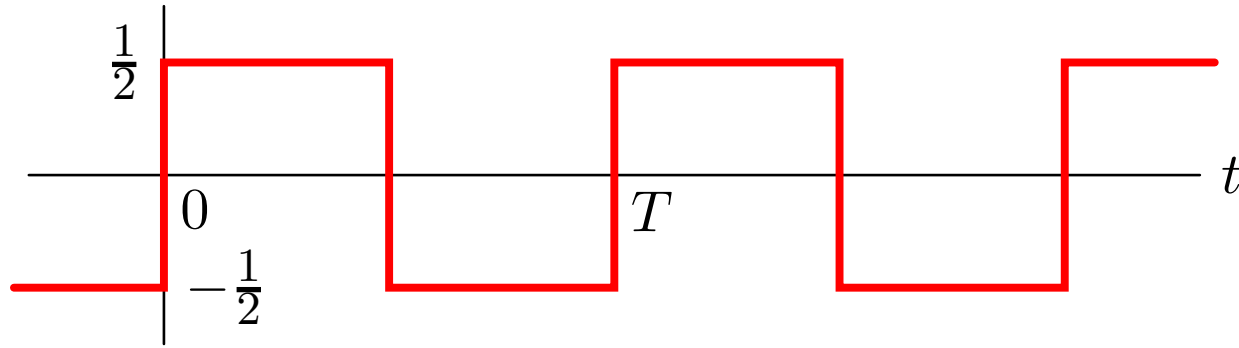

$$x(t) = \sum_{k \text{ odd}} \frac{1}{j\pi k} e^{j\omega_0 kt} ; \quad \omega_0 = \frac{2\pi}{T}$$

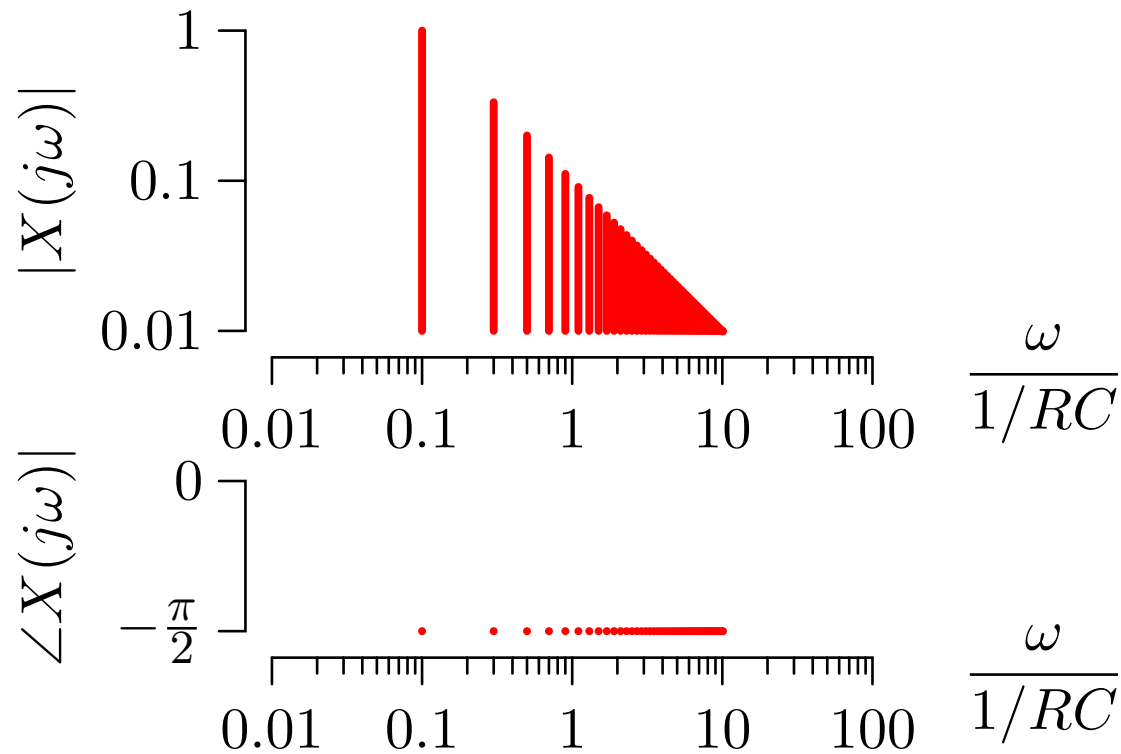

# Lowpass Filtering

Low frequency square wave:  $\omega_0 \ll 1/RC$ .

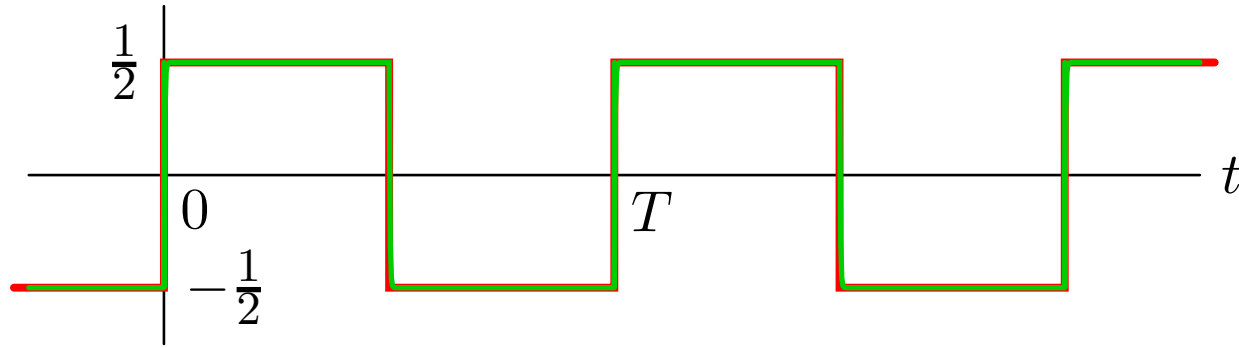

$$x(t) = \sum_{k \text{ odd}} \frac{1}{j\pi k} e^{j\omega_0 k t} ; \quad \omega_0 = \frac{2\pi}{T}$$

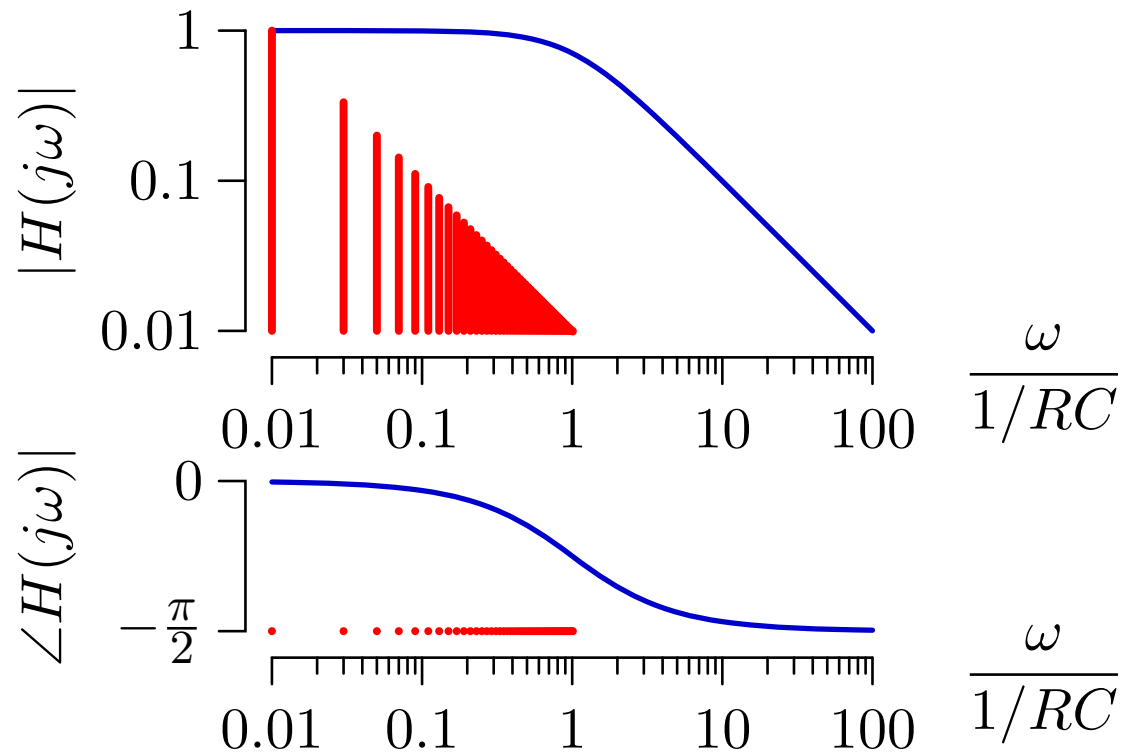

# Lowpass Filtering

Higher frequency square wave:  $\omega_0 < 1/RC$ .

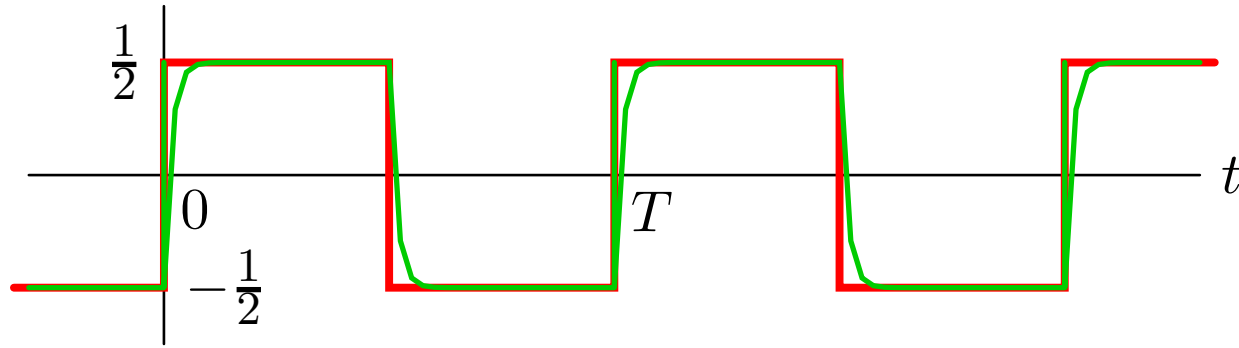

$$x(t) = \sum_{k \text{ odd}} \frac{1}{j\pi k} e^{j\omega_0 k t} ; \quad \omega_0 = \frac{2\pi}{T}$$

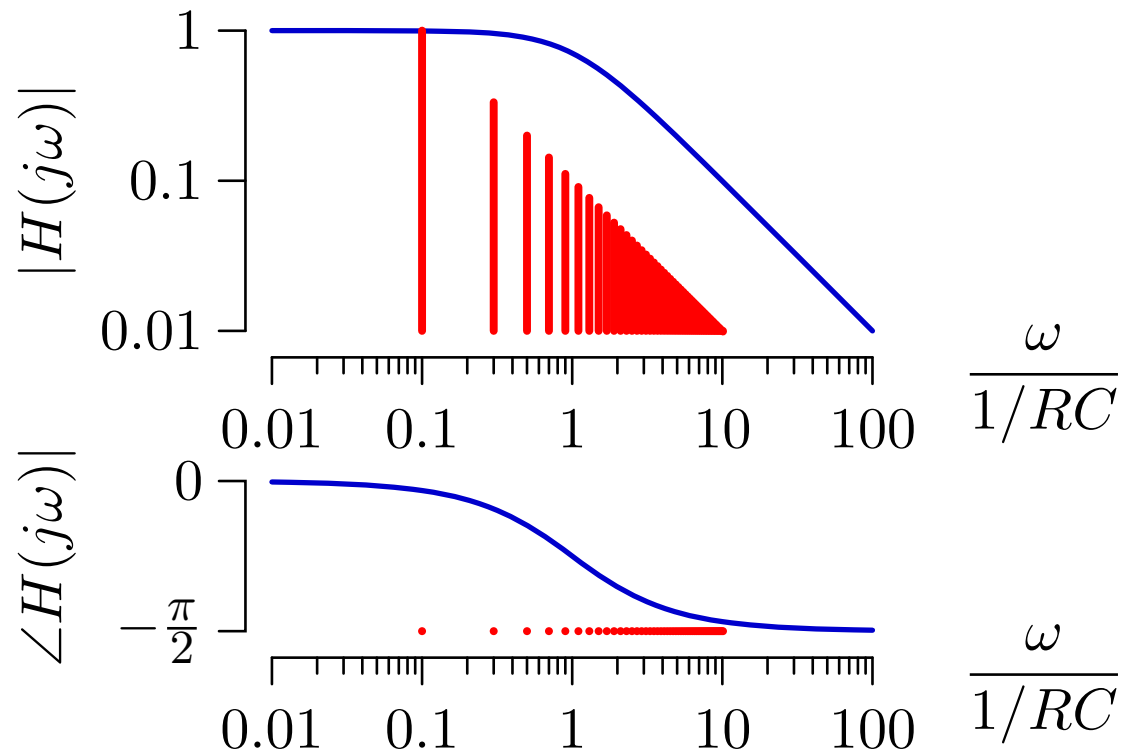

# Lowpass Filtering

Still higher frequency square wave:  $\omega_0 = 1/RC$ .

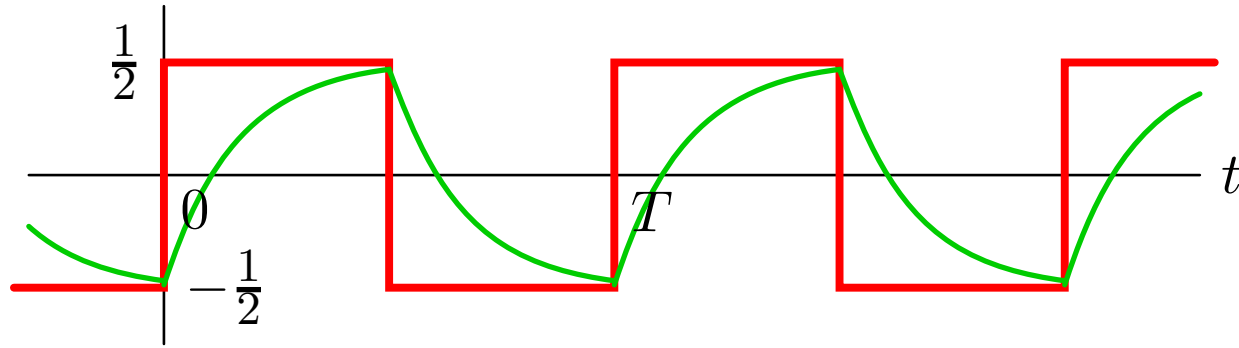

$$x(t) = \sum_{k \text{ odd}} \frac{1}{j\pi k} e^{j\omega_0 k t} ; \quad \omega_0 = \frac{2\pi}{T}$$

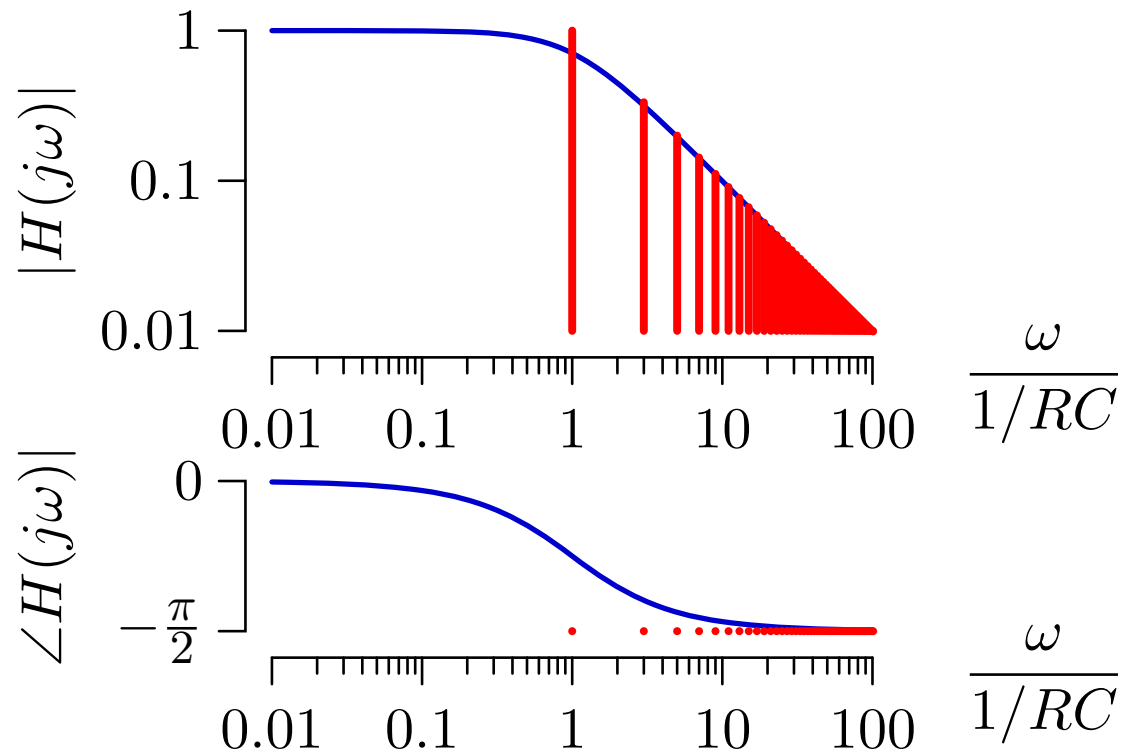



# Lowpass Filtering

High frequency square wave:  $\omega_0 > 1/RC$ .

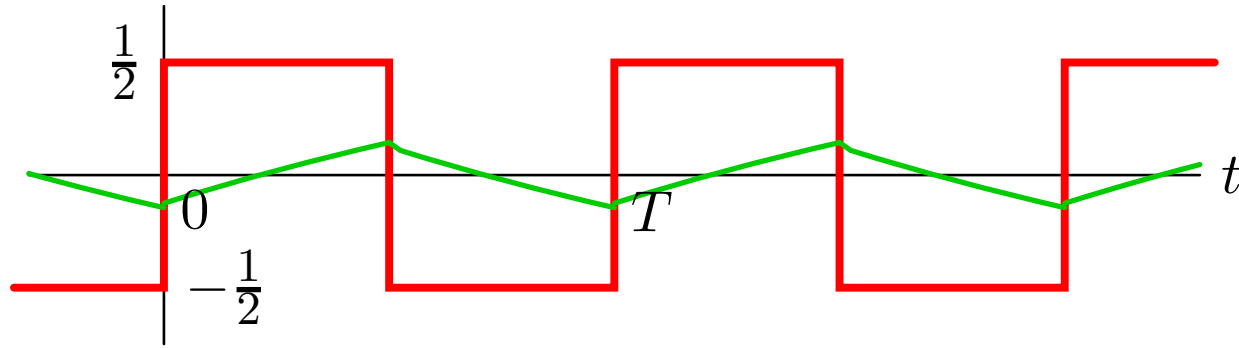

$$x(t) = \sum_{k \text{ odd}} \frac{1}{j\pi k} e^{j\omega_0 k t} ; \quad \omega_0 = \frac{2\pi}{T}$$

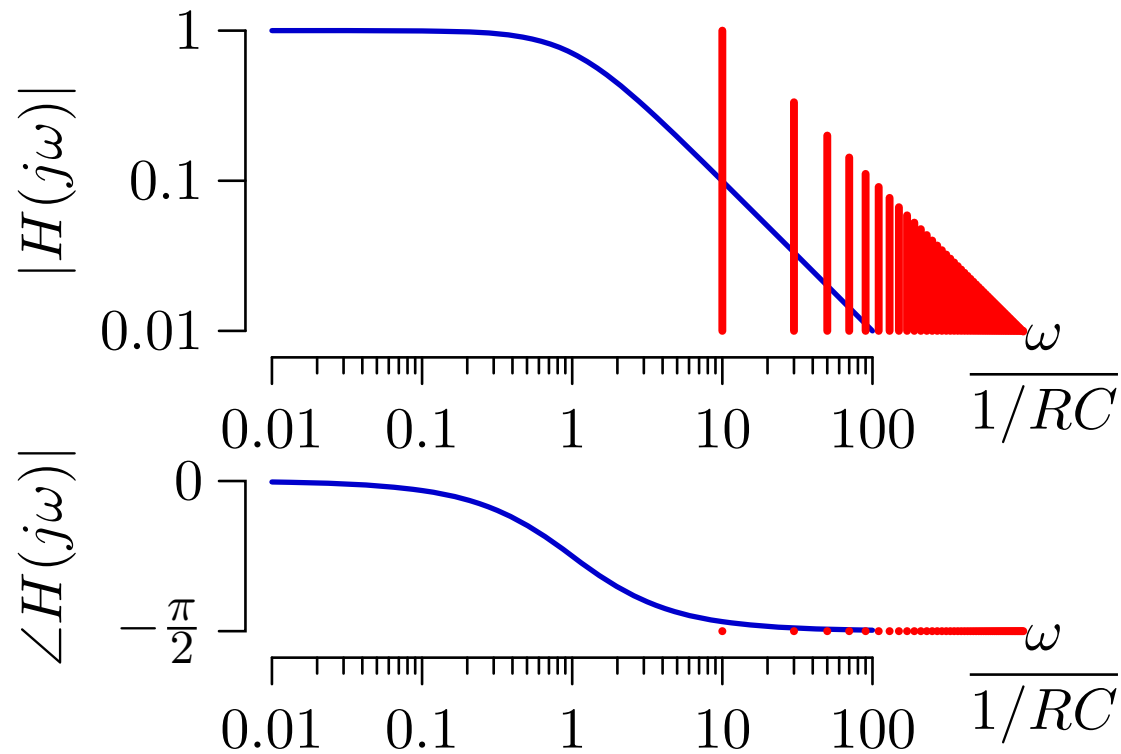

# Source-Filter Model of Speech Production

---

Vibrations of the vocal cords are “filtered” by the mouth and nasal cavities to generate speech.

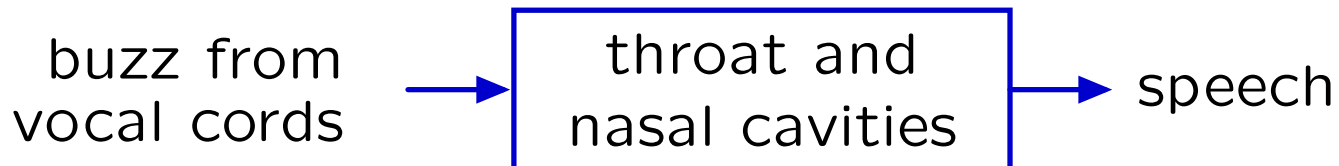
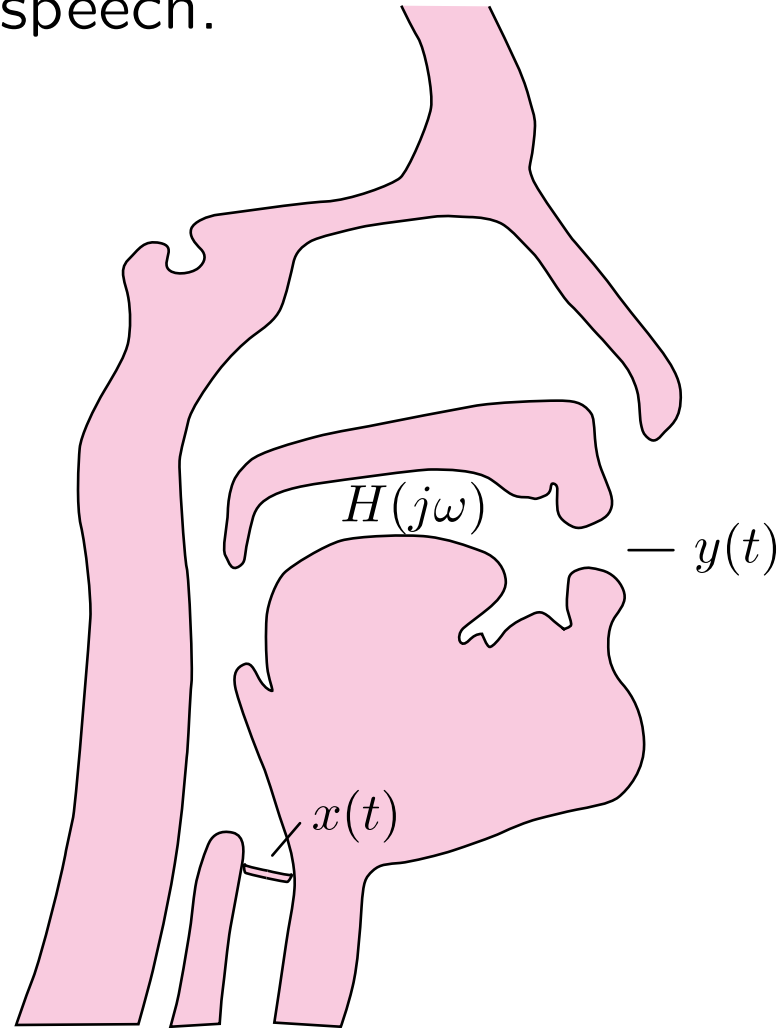

# Filtering

---

LTI systems “filter” signals based on their frequency content.

Fourier transforms represent signals as sums of complex exponentials.

$$x(t) = \frac{1}{2\pi} \int_{-\infty}^{\infty} X(j\omega) e^{j\omega t} d\omega$$

Complex exponentials are eigenfunctions of LTI systems.

$$e^{j\omega t} \rightarrow H(j\omega) e^{j\omega t}$$

LTI systems “filter” signals by adjusting the amplitudes and phases of each frequency component.

$$x(t) = \frac{1}{2\pi} \int_{-\infty}^{\infty} X(j\omega) e^{j\omega t} d\omega \rightarrow y(t) = \frac{1}{2\pi} \int_{-\infty}^{\infty} H(j\omega) X(j\omega) e^{j\omega t} d\omega$$

# Filtering

---

Systems can be designed to selectively pass certain frequency bands.

Examples: low-pass filter (LPF) and high-pass filter (HPF).

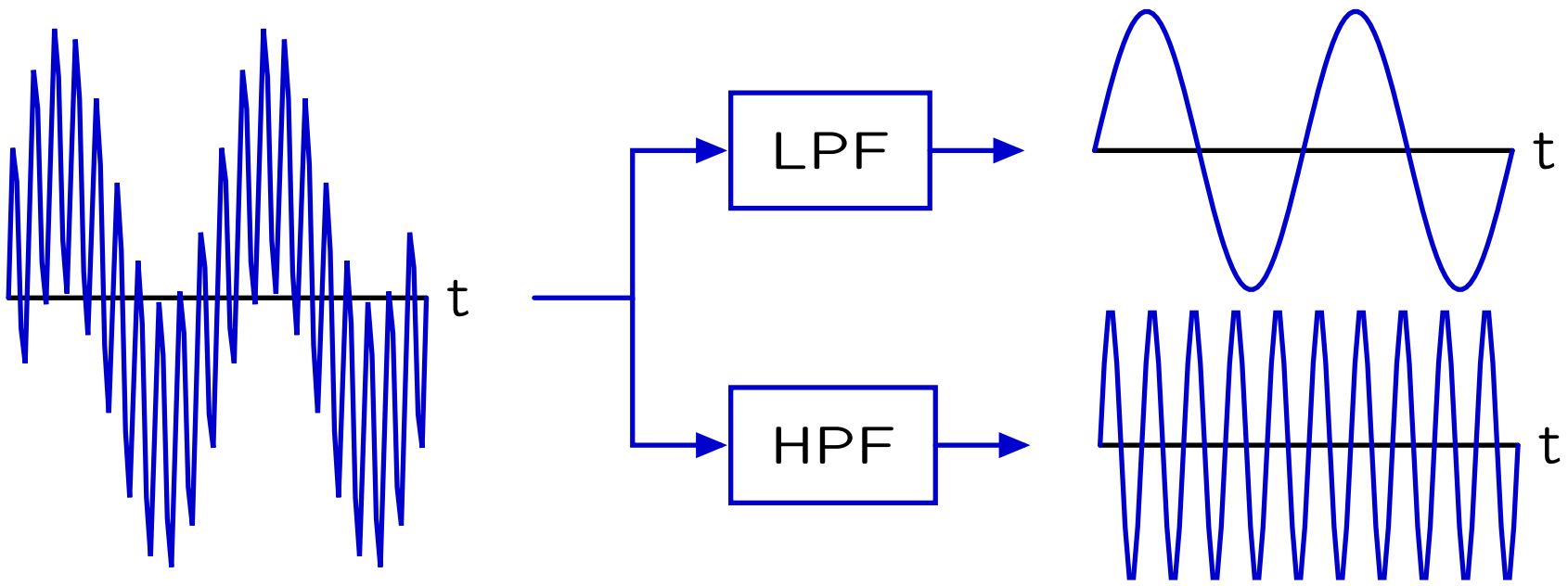
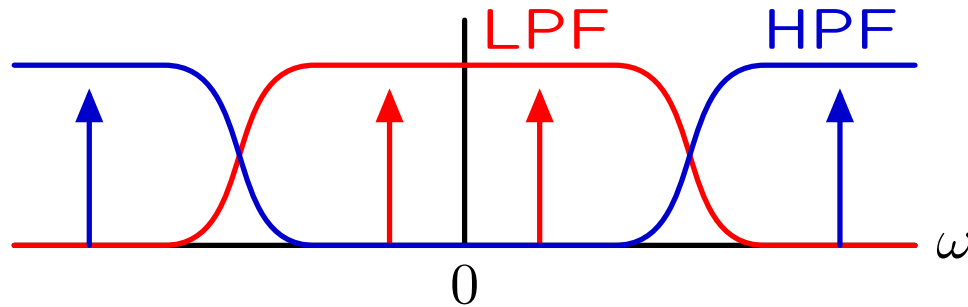

# Filtering Example: Electrocardiogram

---

An electrocardiogram is a record of electrical potentials that are generated by the heart and measured on the surface of the chest.

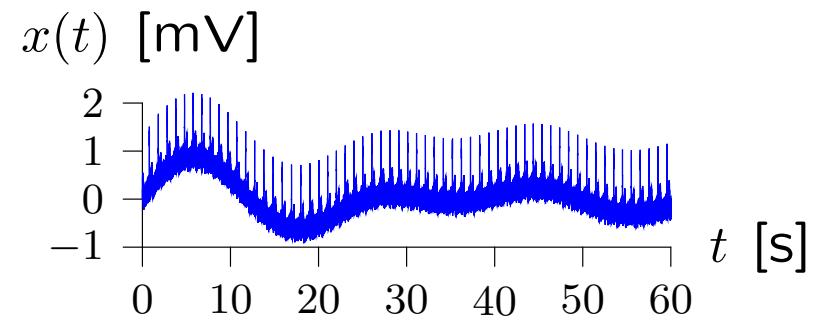
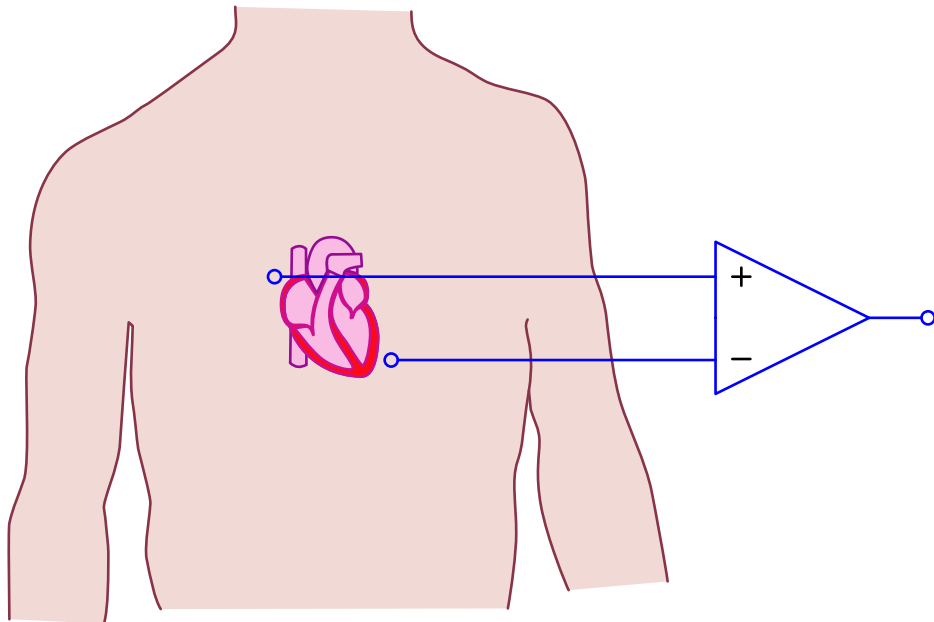

# Filtering Example: Electrocardiogram

---

In addition to picking up electrical responses of the heart, electrodes on the skin also pick up a variety of other electrical signals that we regard as “noise.”

We wish to design a filter to eliminate the noise.

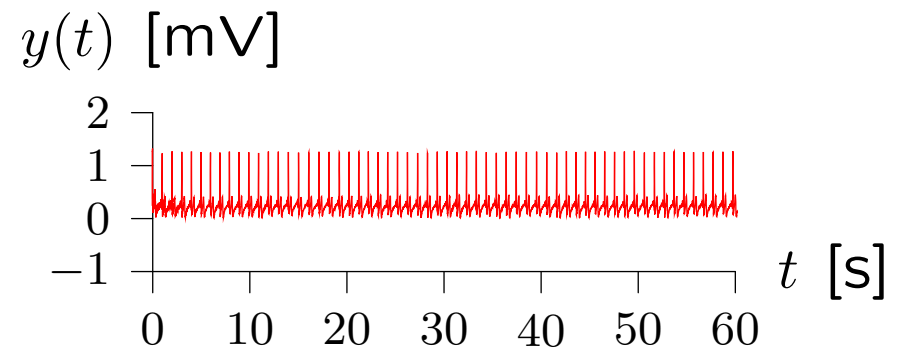
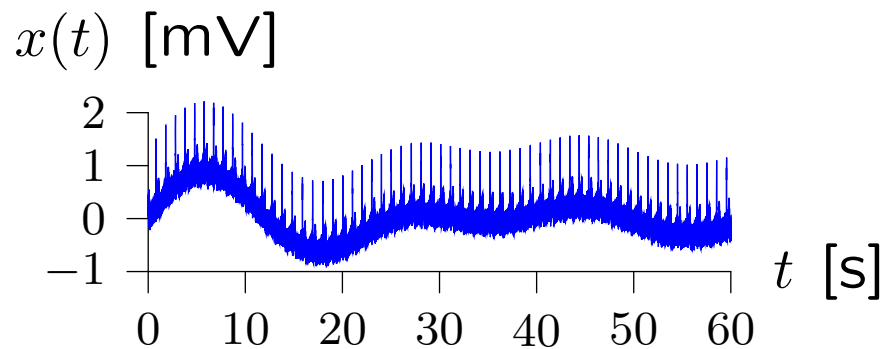

# Filtering Example: Electrocardiogram

We can identify the “noise” by breaking the electrocardiogram into frequency components using the Fourier transform.

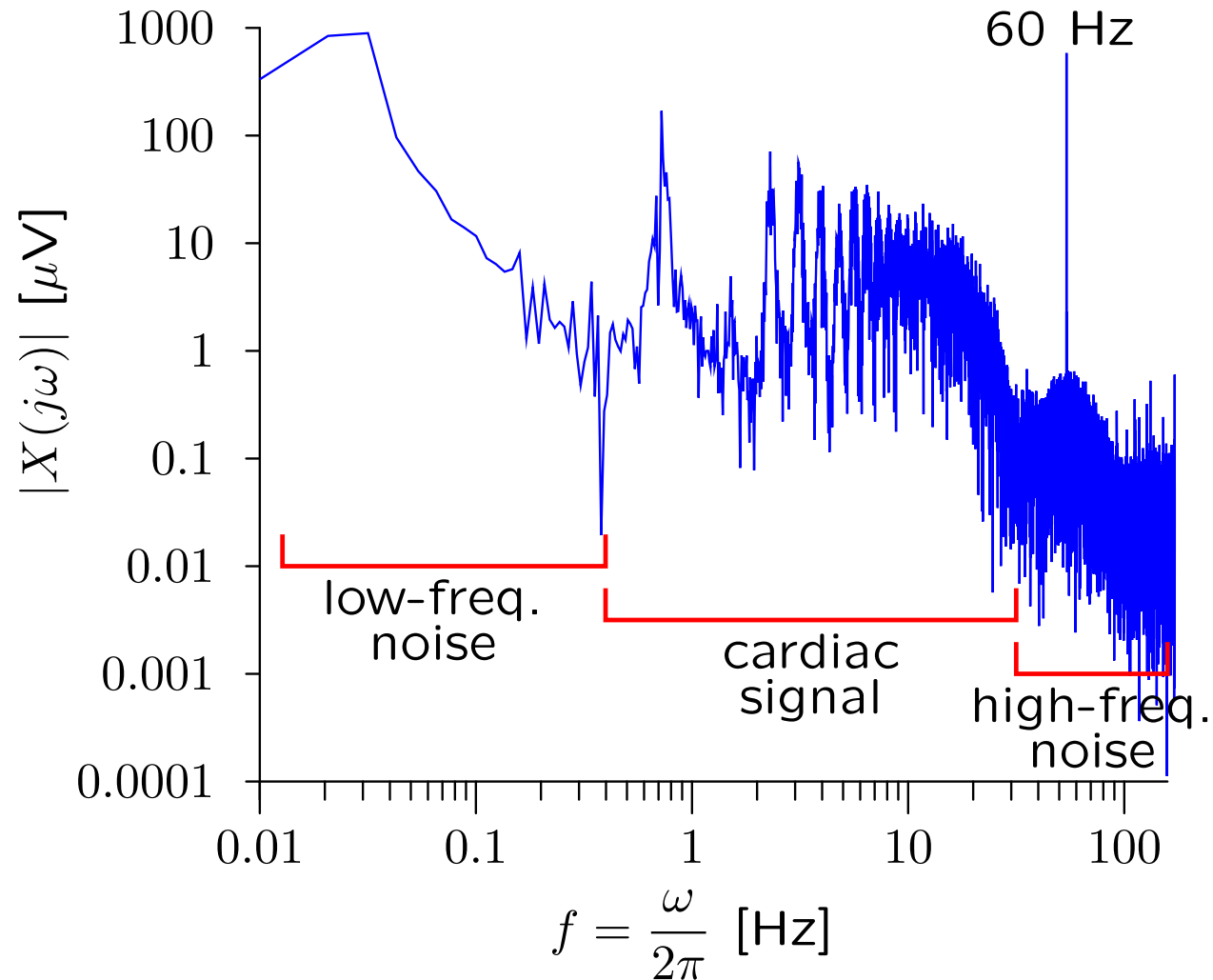

# Filtering Example: Electrocardiogram

---

Filter design: low-pass filter + high-pass filter + notch.

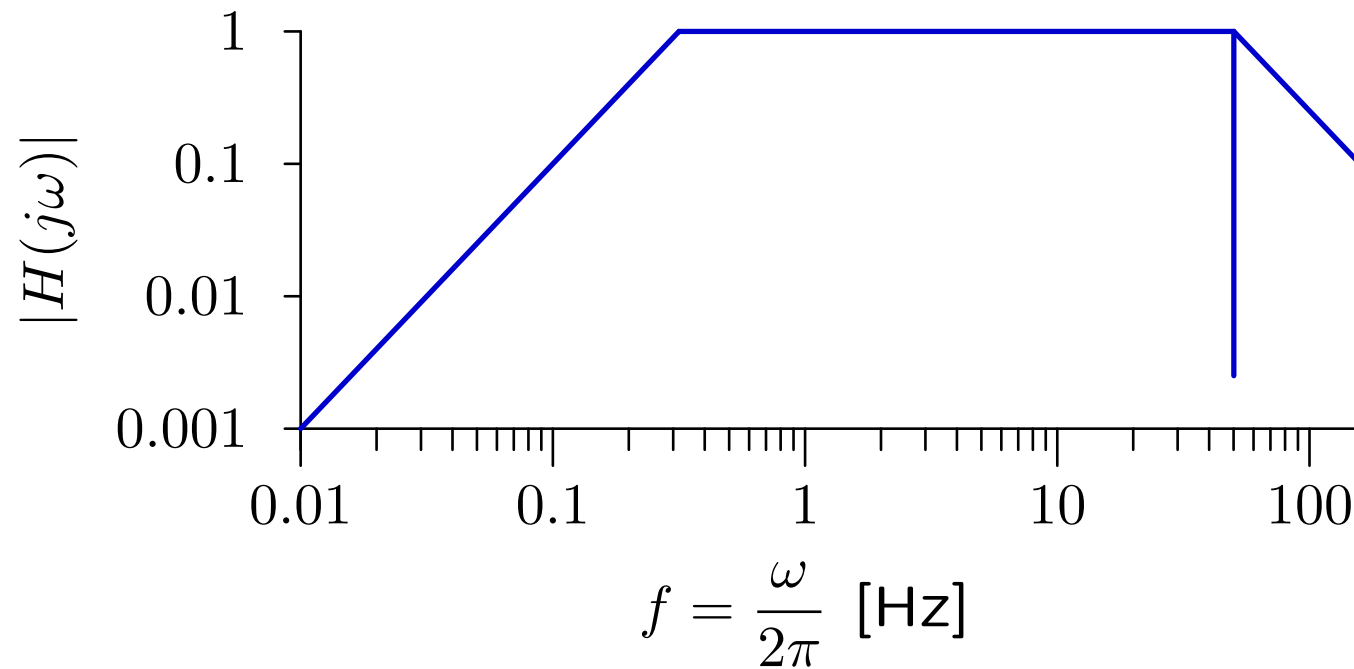



# Electrocardiogram: Check Yourself

---

Which poles and zeros are associated with

- the high-pass filter?
- the low-pass filter?
- the notch filter?

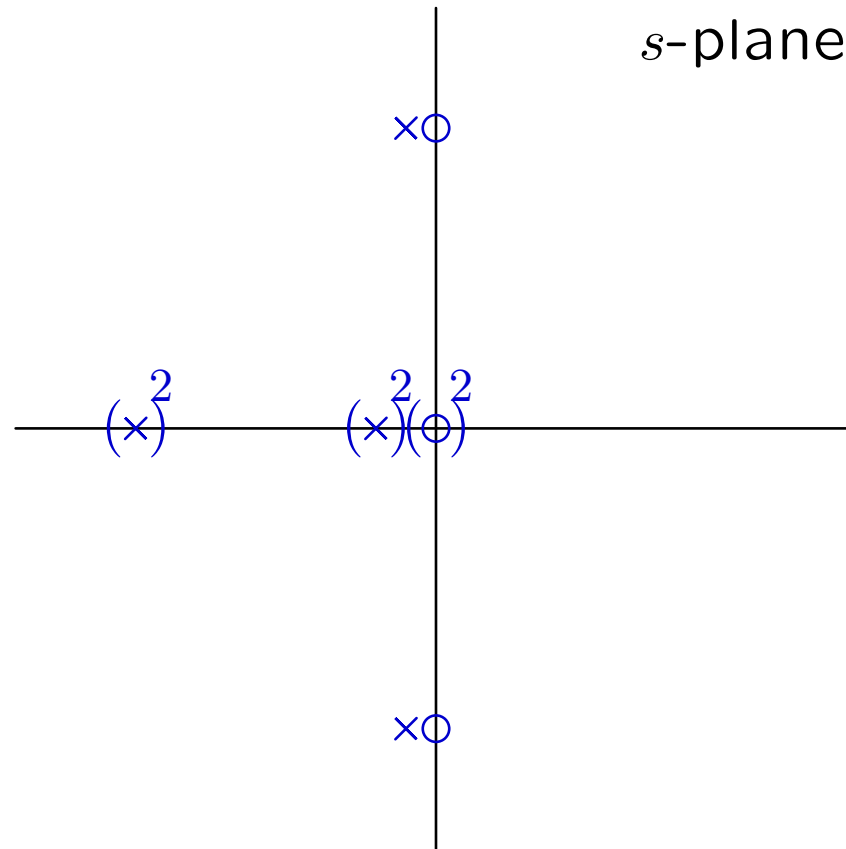

# Electrocardiogram: Check Yourself

---

Which poles and zeros are associated with

- the high-pass filter?
- the low-pass filter?
- the notch filter?

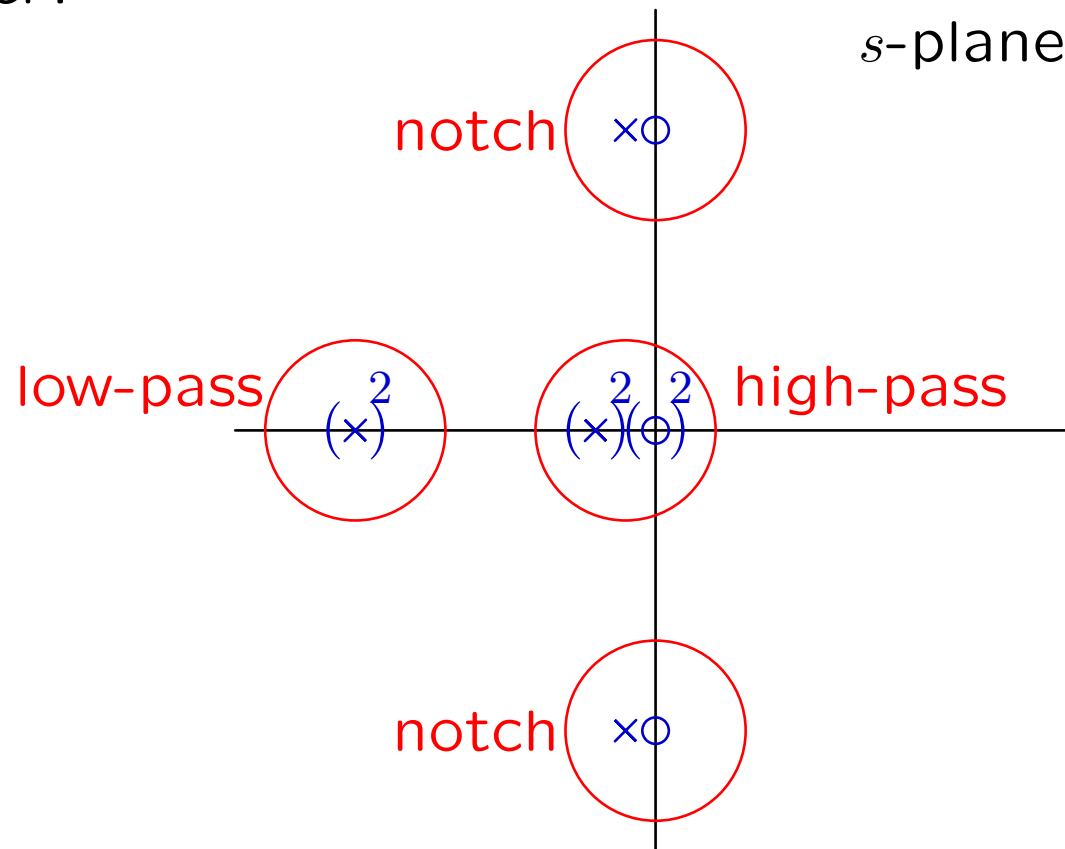

## Filtering Example: Electrocardiogram

---

By placing the poles of the notch filter very close to the zeros, the width of the notch can be made quite small.

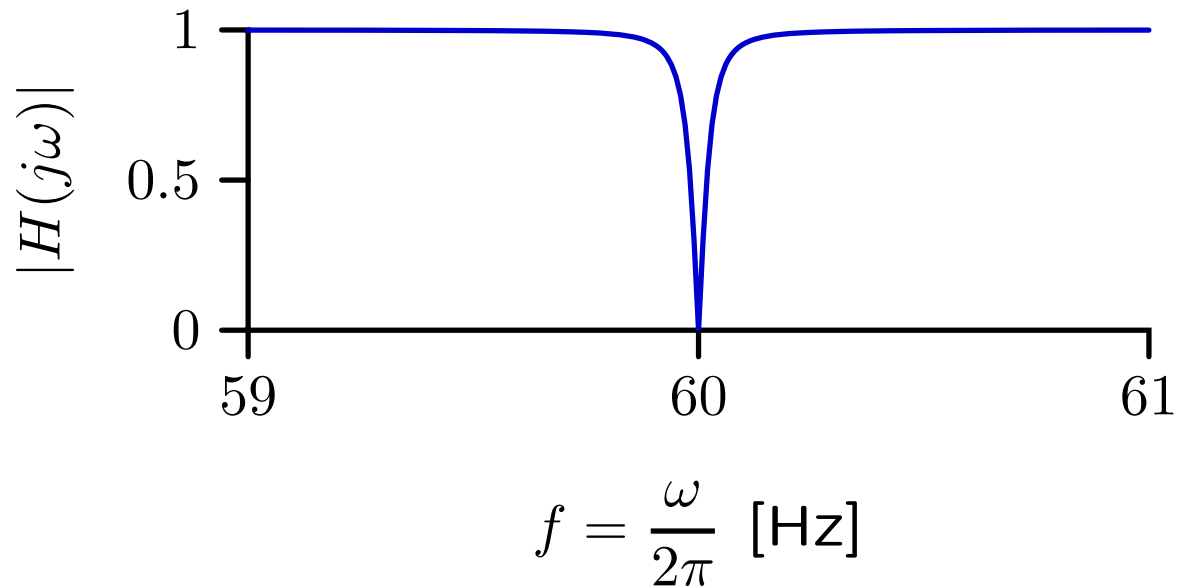

# Filtering Example: Electrocardiogram

Comparison of filtered and unfiltered electrocardiograms.

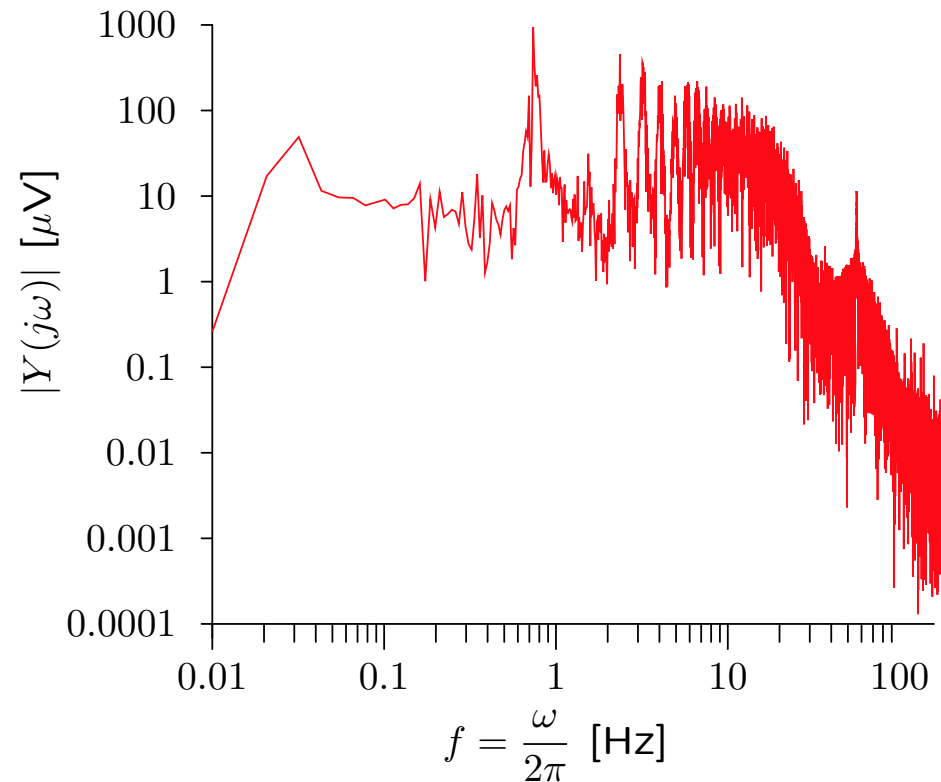
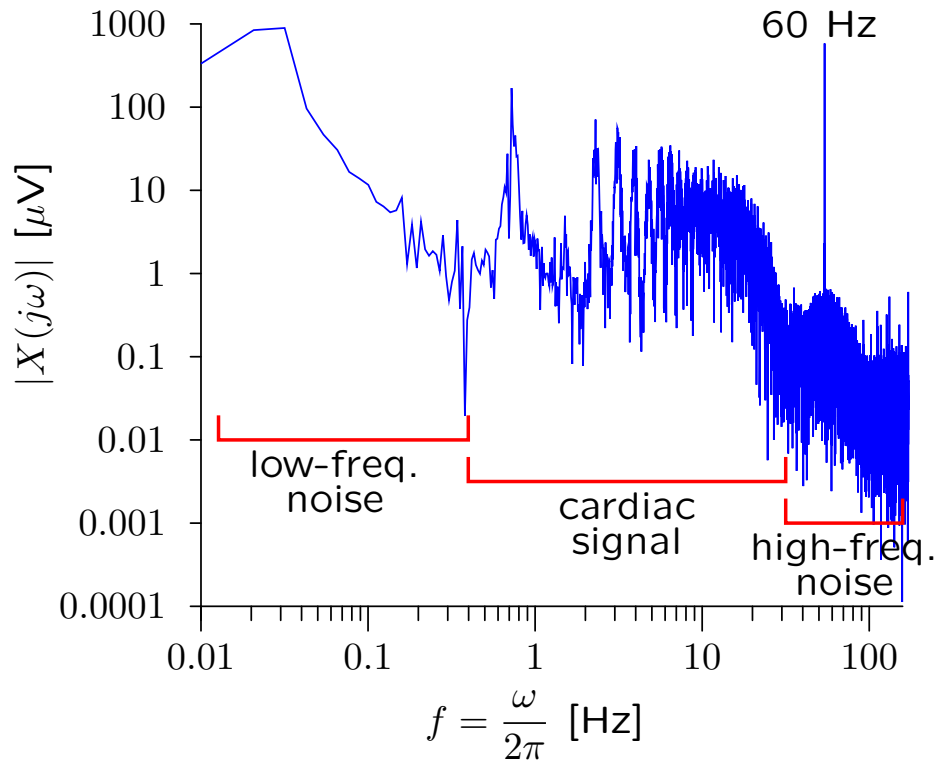
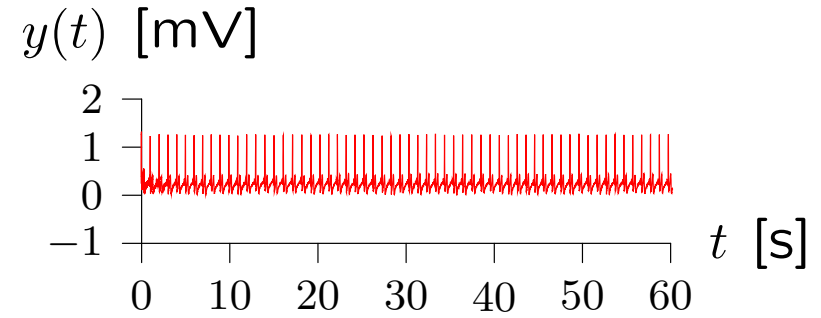
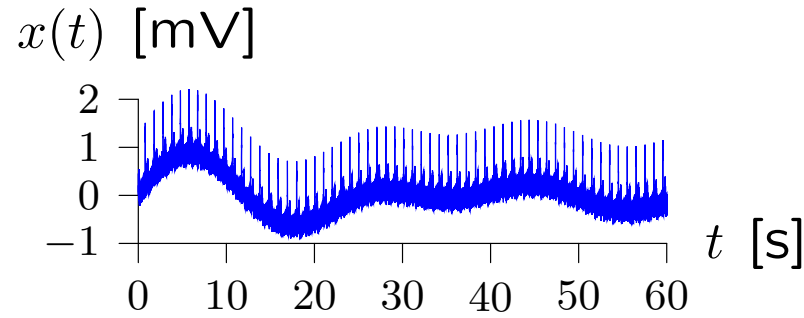

# Filtering Example: Electrocardiogram

---

Reducing the frequency components that are not generated by the heart simplifies the output, making it easier to diagnose cardiac problems.

Unfiltered ECG

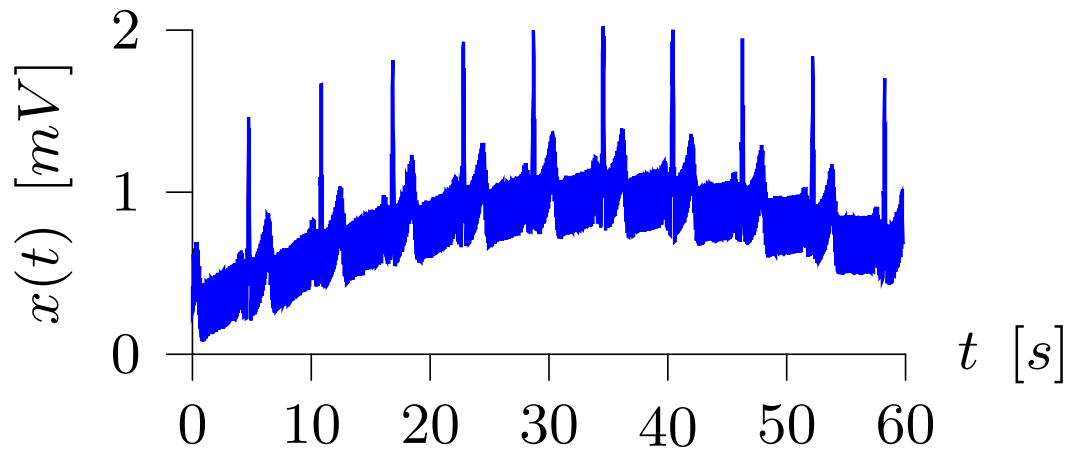

Filtered ECG

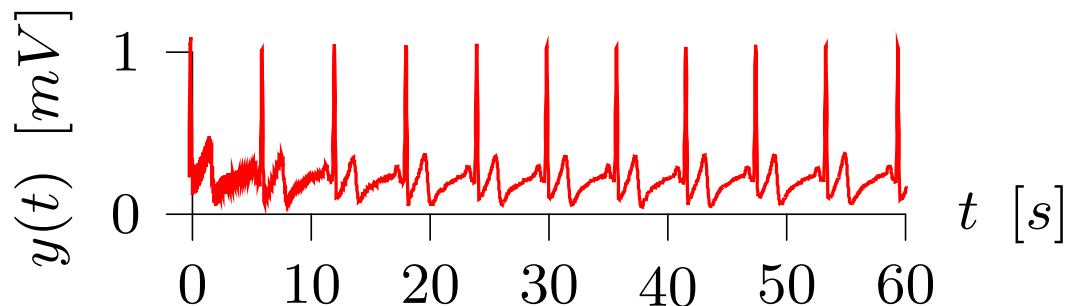

# Continuous-Time Fourier Transform: Summary

---

Fourier transforms represent signals by their frequency content.

→ useful for many signals, e.g., electrocardiogram.

→ motivates representing a system as a filter.

→ useful for many systems.

# Visualizing the Fourier Transform

---

Fourier transforms provide alternate **views** of signals.

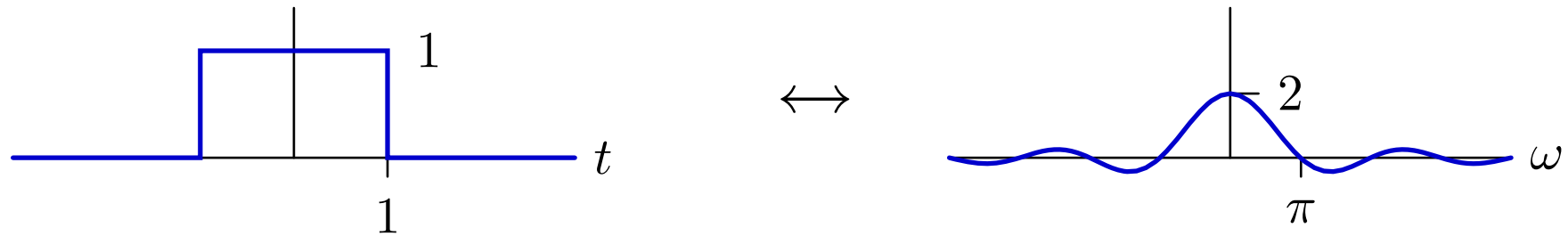

Pulses contain all frequencies except harmonics of  $2\pi/\text{width}$ .

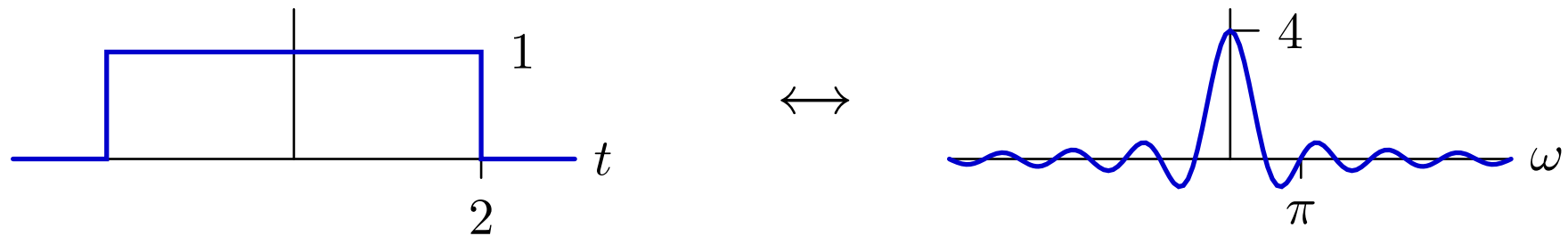

Wider pulses contain more low frequencies than narrow pulses.

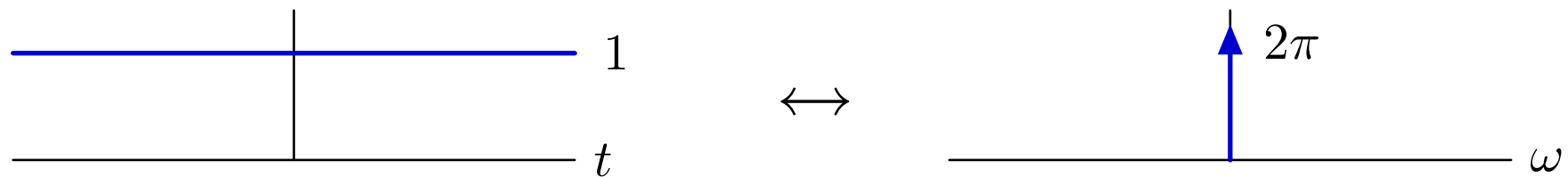

Constants (in time) contain only frequencies at  $\omega = 0$ .

# Fourier Transforms in Physics: Diffraction

---

A diffraction grating breaks a laser beam input into multiple beams.

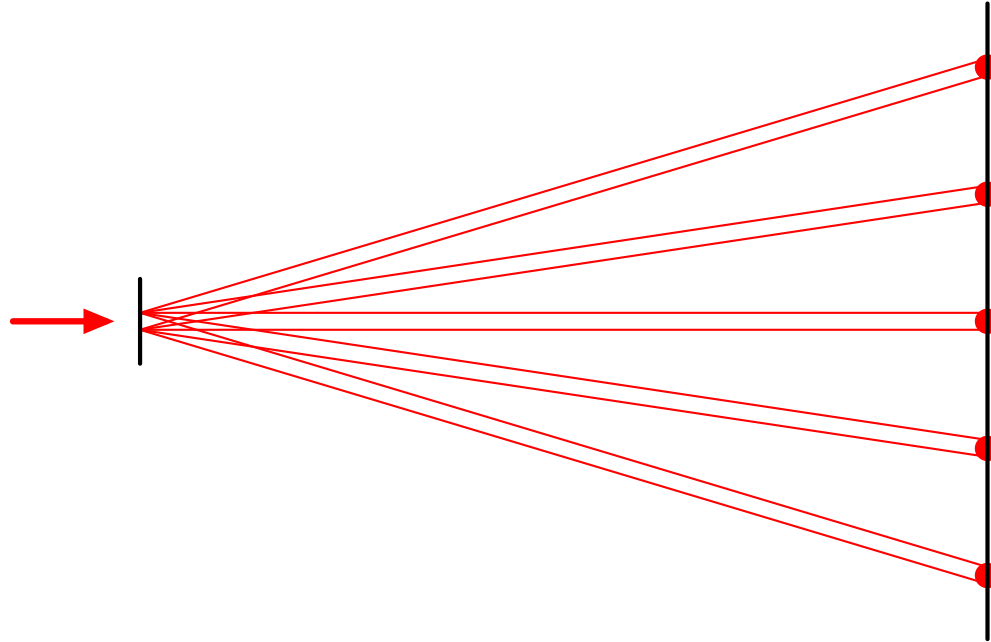

Demonstration.



# Fourier Transforms in Physics: Diffraction

---

The grating has a periodic structure (period =  $D$ ).

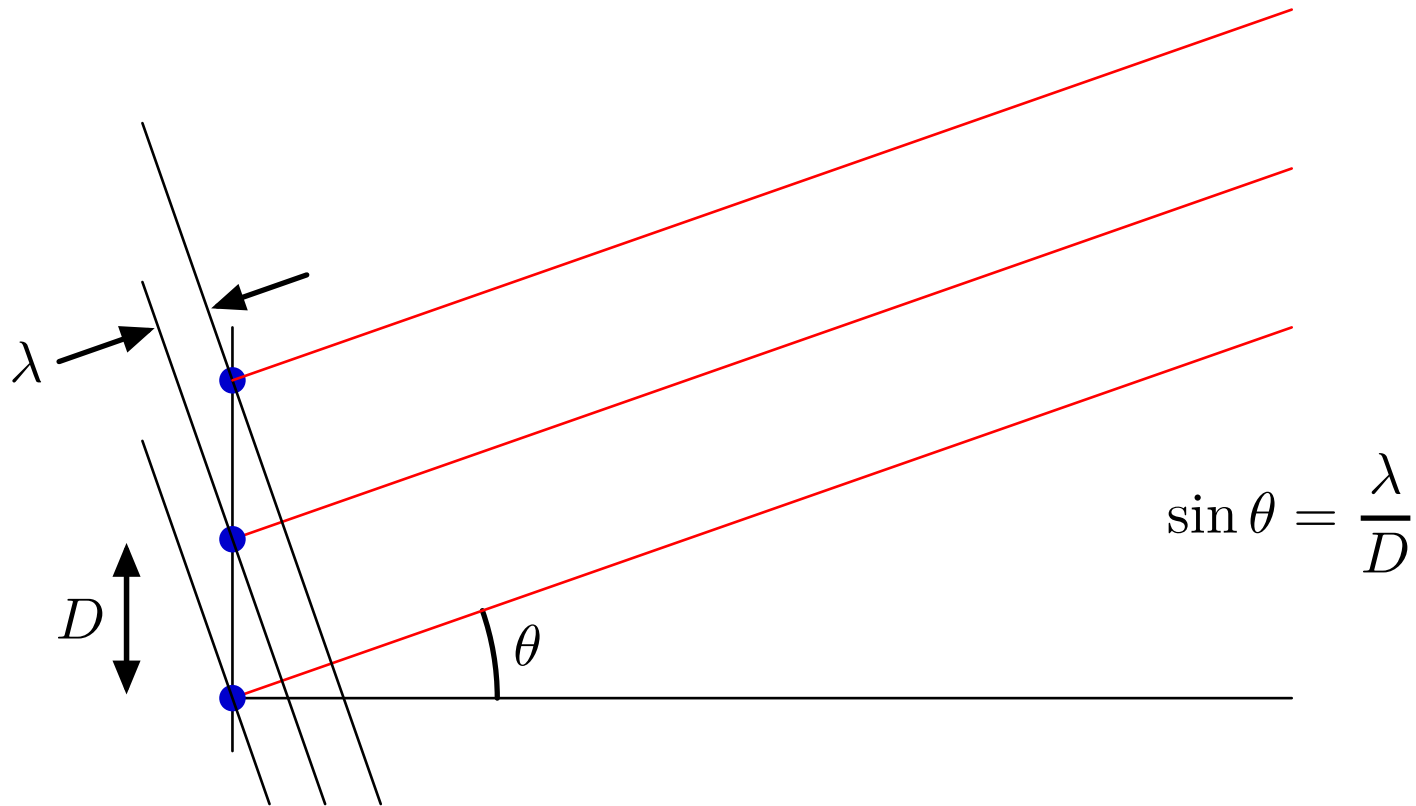

The “far field” image is formed by interference of scattered light.

Viewed from angle  $\theta$ , the scatterers are separated by  $D \sin \theta$ .

If this distance is an integer number of wavelengths  $\lambda \rightarrow$  constructive interference.

# Fourier Transforms in Physics: Diffraction

---

CD demonstration.

## Check Yourself

CD demonstration.

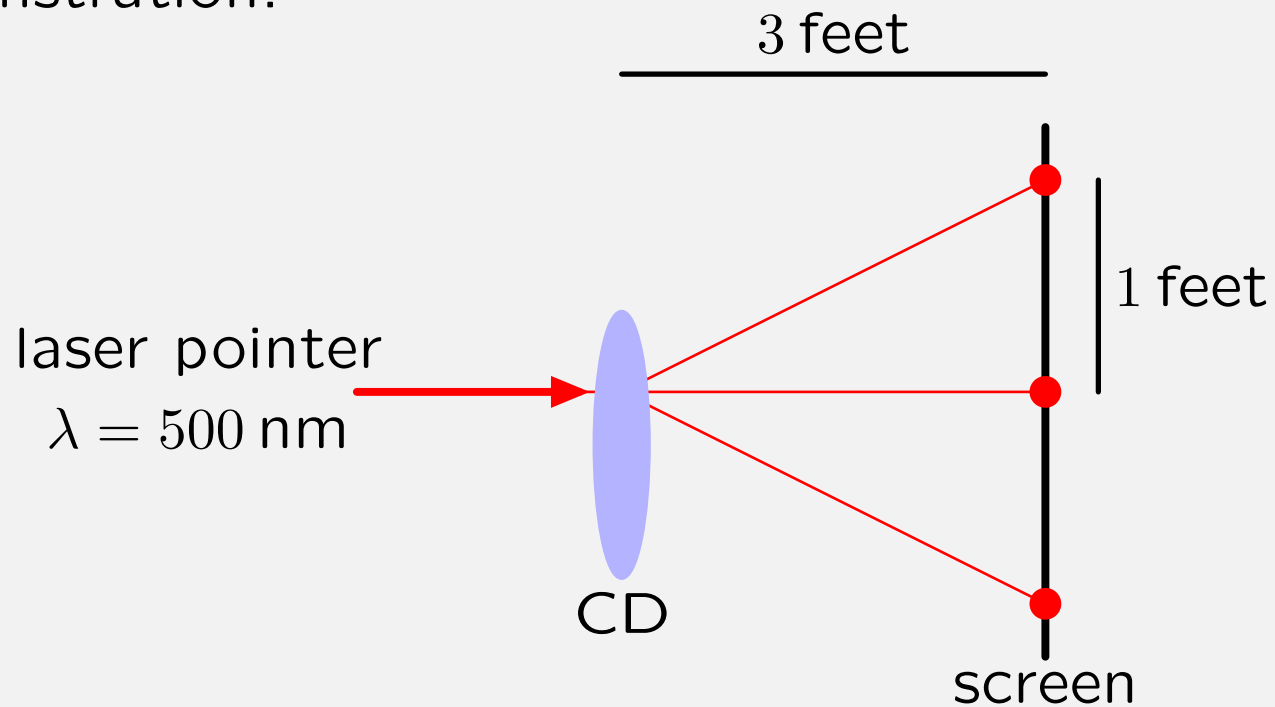

What is the spacing of the tracks on the CD?

1. 160 nm
2. 1600 nm
3.  $16\mu\text{m}$
4.  $160\mu\text{m}$

## Check Yourself

---

What is the spacing of the tracks on the CD?

---

grating	$\tan \theta$	$\theta$	$\sin \theta$	$D = \frac{500 \text{ nm}}{\sin \theta}$	manufacturing spec.
CD	$\frac{1}{3}$	0.32	0.31	1613 nm	1600 nm

---

# Check Yourself

Demonstration.

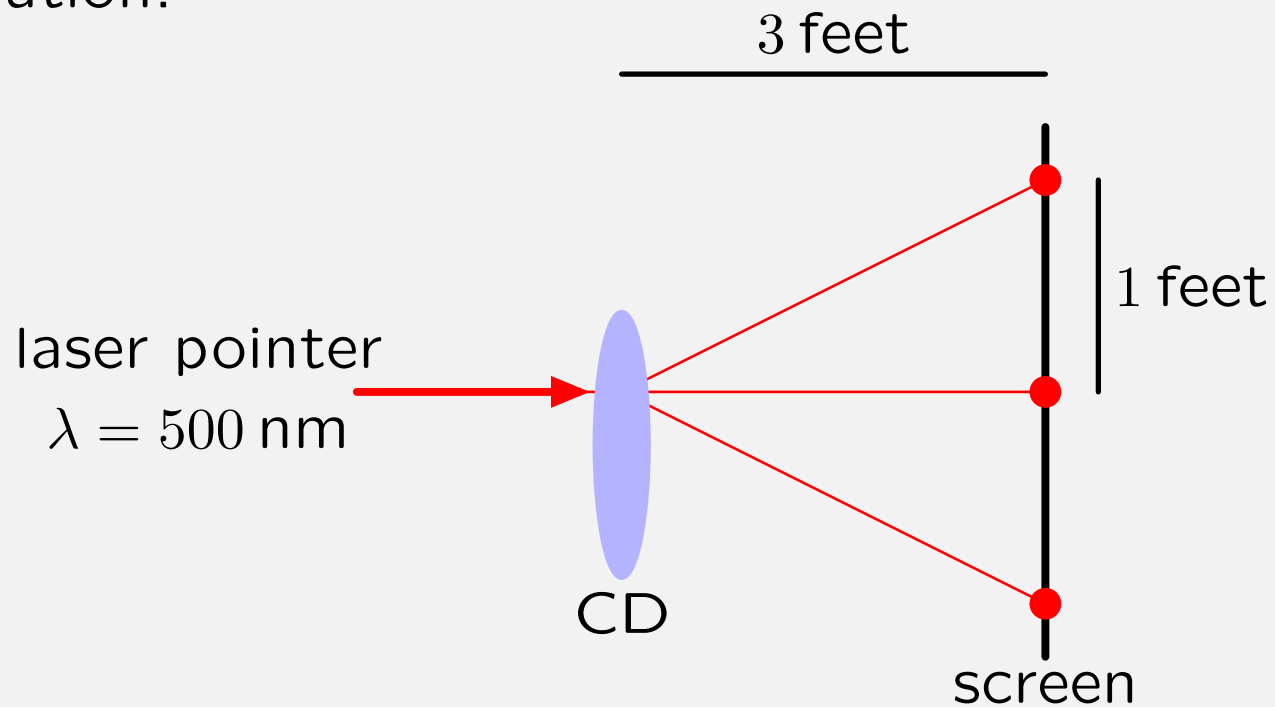

What is the spacing of the tracks on the CD? **2.**

1. 160 nm

**2. 1600 nm**

3.  $16 \mu\text{m}$

4.  $160 \mu\text{m}$

# Fourier Transforms in Physics: Diffraction

---

DVD demonstration.

## Check Yourself

DVD demonstration.

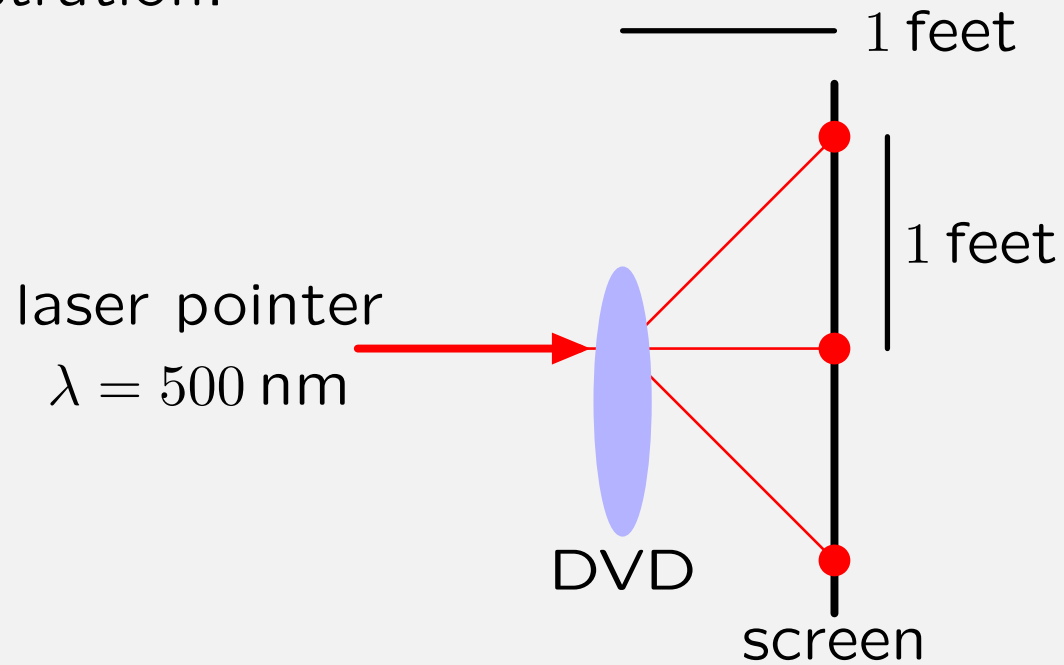

What is track spacing on DVD divided by that for CD?

1.  $4\times$

2.  $2\times$

3.  $\frac{1}{2}\times$

4.  $\frac{1}{4}\times$

## Check Yourself

---

What is spacing of tracks on DVD divided by that for CD?

---

grating	$\tan \theta$	$\theta$	$\sin \theta$	$D = \frac{500 \text{ nm}}{\sin \theta}$	manufacturing spec.
CD	$\frac{1}{3}$	0.32	0.31	1613 nm	1600 nm
DVD	1	0.78	0.71	704 nm	740 nm

---



## Check Yourself

DVD demonstration.

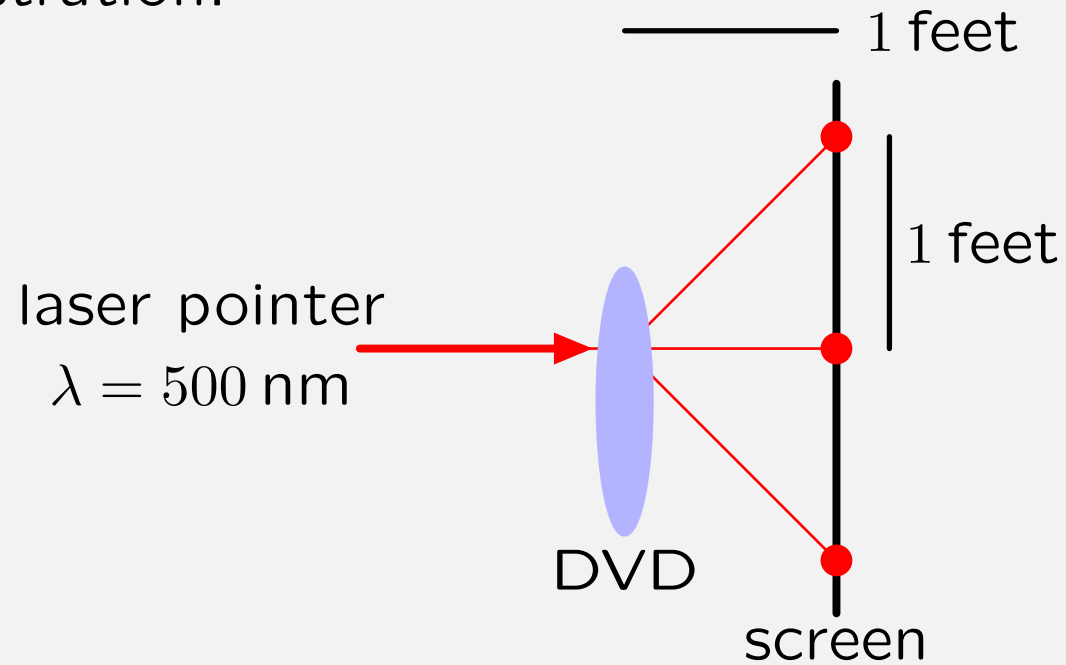

What is track spacing on DVD divided by that for CD? **3**

1.  $4\times$

2.  $2\times$

3.  $\frac{1}{2}\times$

4.  $\frac{1}{4}\times$

# Fourier Transforms in Physics: Diffraction

---

Macroscopic information in the far field provides microscopic (invisible) information about the grating.

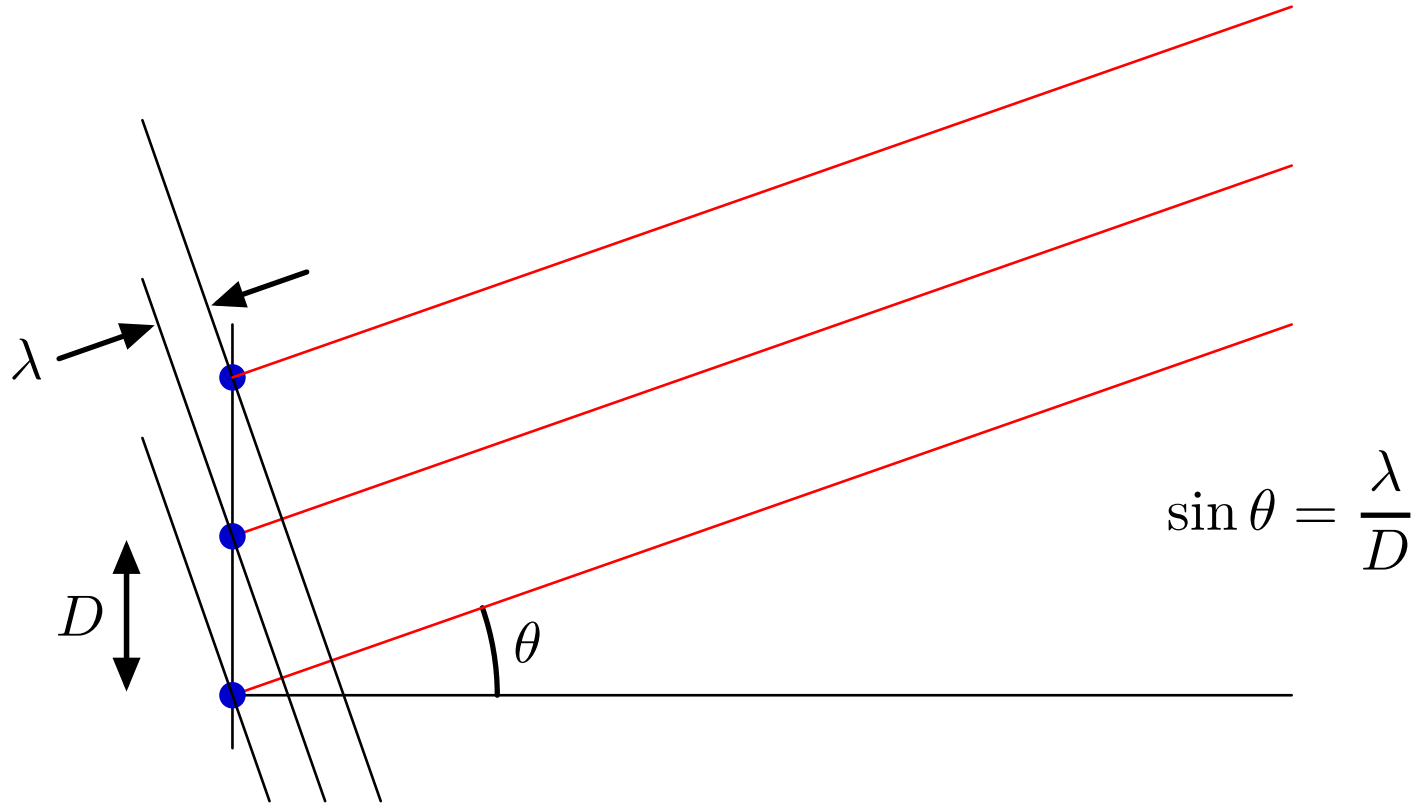

# Fourier Transforms in Physics: Crystallography

---

What if the target is more complicated than a grating?

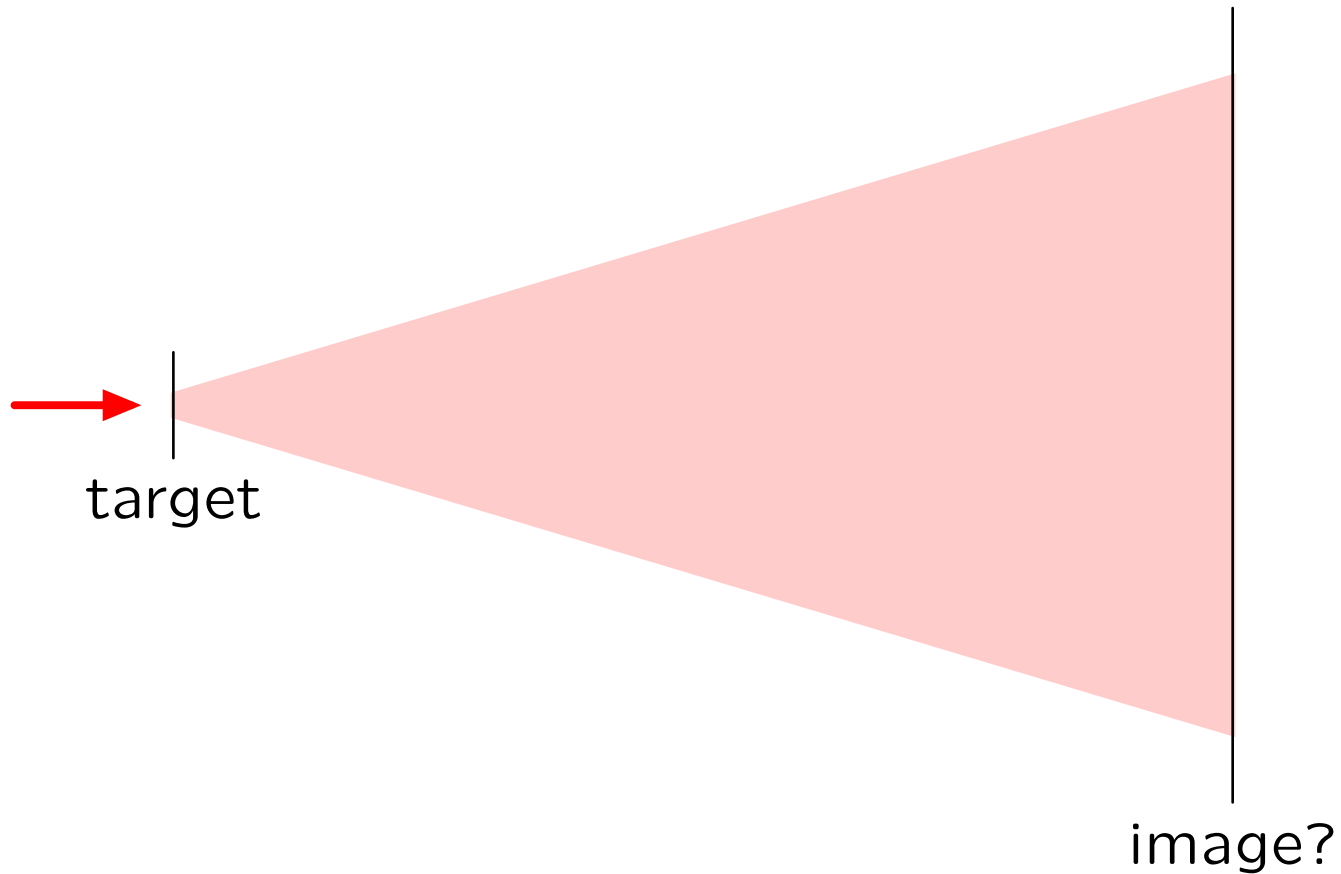

# Fourier Transforms in Physics: Crystallography

---

Part of image at angle  $\theta$  has contributions for all parts of the target.

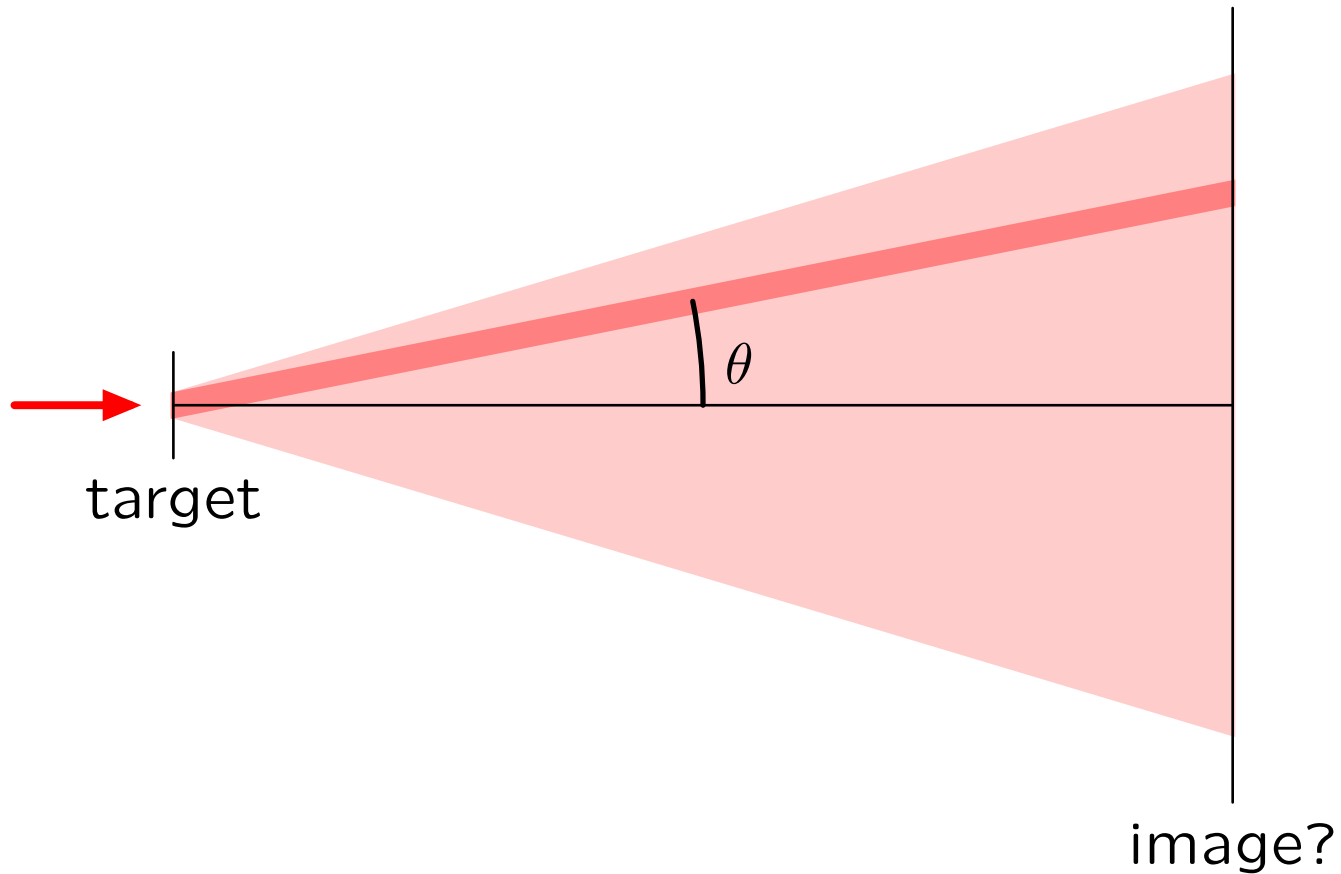

# Fourier Transforms in Physics: Crystallography

---

The phase of light scattered from different parts of the target undergo different amounts of phase delay.

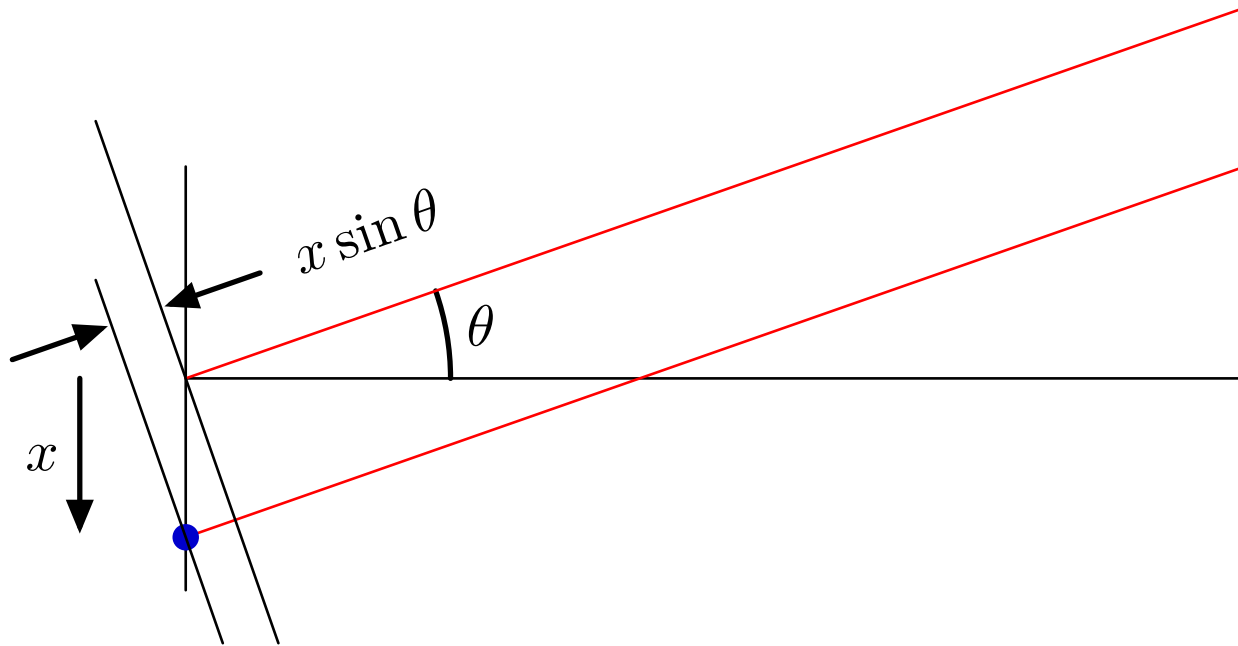

Phase at a point  $x$  is delayed (i.e., negative) relative to that at 0:

$$\phi = -2\pi \frac{x \sin \theta}{\lambda}$$

# Fourier Transforms in Physics: Crystallography

---

Total light  $F(\theta)$  at angle  $\theta$  is the integral of amount scattered from each part of the target ( $f(x)$ ) appropriately shifted in phase.

$$F(\theta) = \int f(x) e^{-j2\pi \frac{x \sin \theta}{\lambda}} dx$$

Assume small angles so  $\sin \theta \approx \theta$ .

Let  $\omega = 2\pi \frac{\theta}{\lambda}$ .

Then the pattern of light at the detector is

$$F(\omega) = \int f(x) e^{-j\omega x} dx$$

which is the Fourier transform of  $f(x)$  !

# Fourier Transforms in Physics: Diffraction

There is a Fourier transform relation between this structure and the far-field intensity pattern.

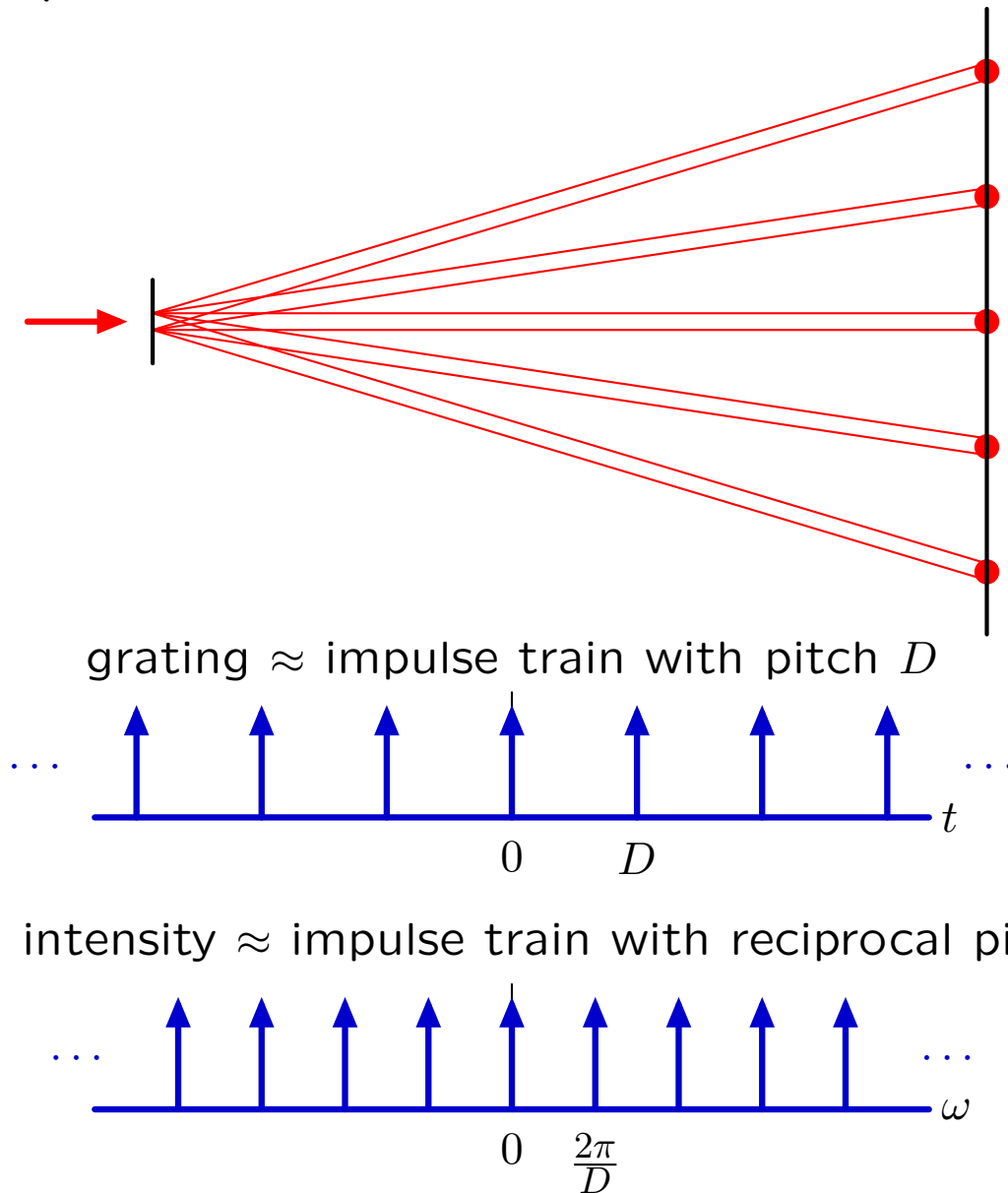

# Impulse Train

---

The Fourier transform of an impulse train is an impulse train.

$$x(t) = \sum_{k=-\infty}^{\infty} \delta(t - kT)$$

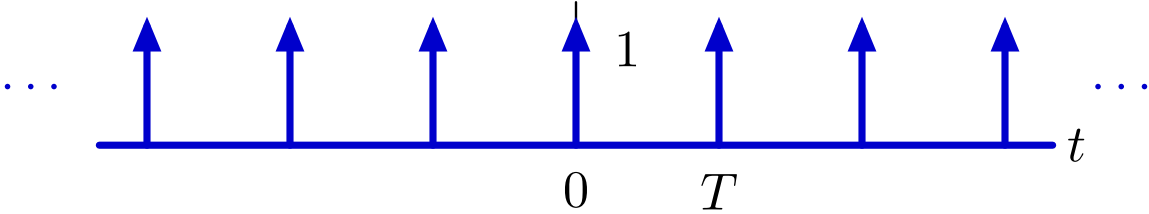

$$a_k = \frac{1}{T} \quad \forall k$$

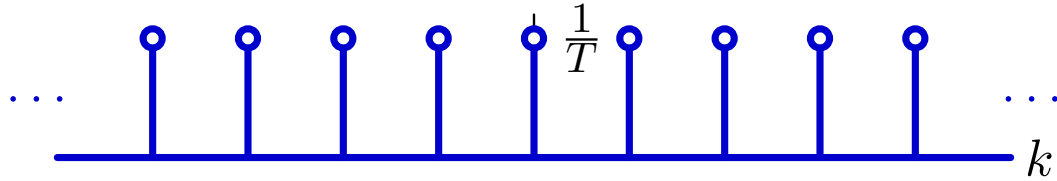

$$X(j\omega) = \sum_{k=-\infty}^{\infty} \frac{2\pi}{T} \delta(\omega - k\frac{2\pi}{T})$$

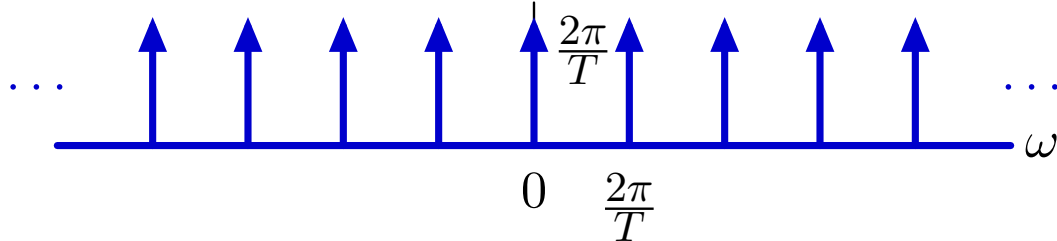



# Two Dimensions

---

Demonstration: 2D grating.

# An Historic Fourier Transform

---

Taken by Rosalind Franklin, this image sparked Watson and Crick's insight into the double helix.

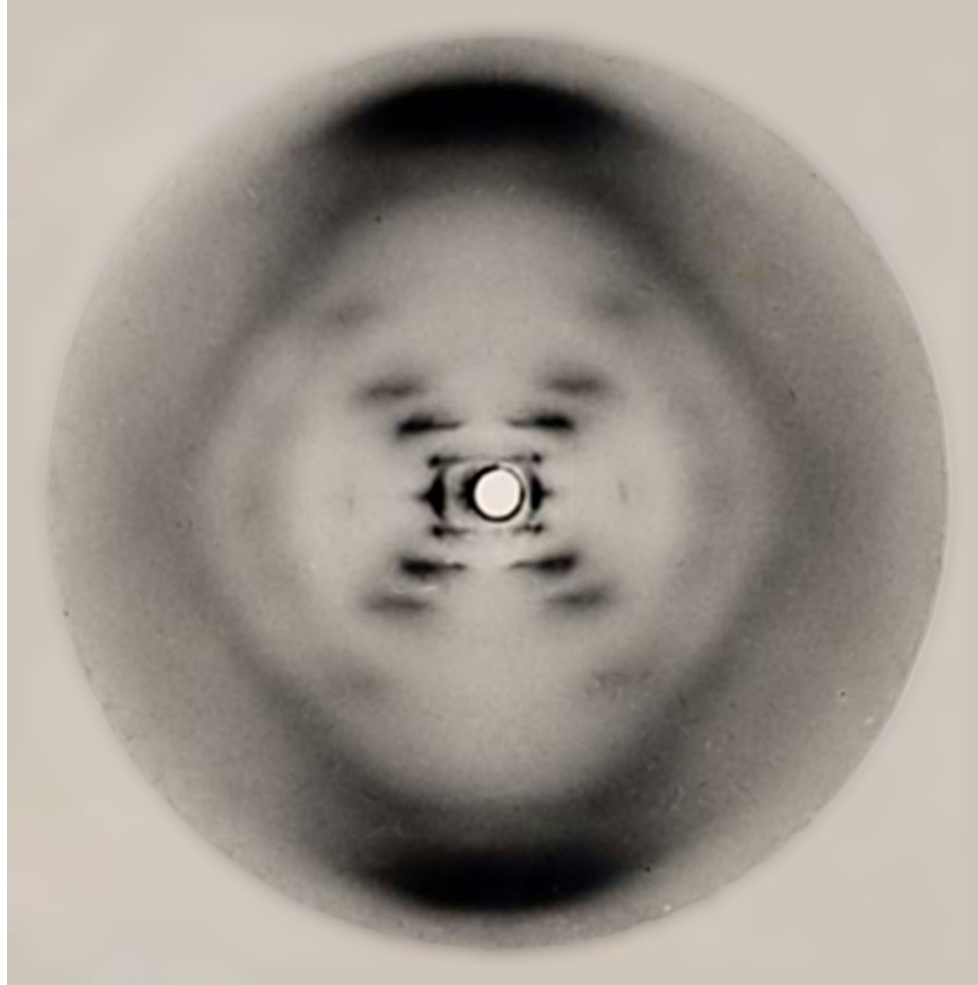

© Source unknown. All rights reserved.  
This content is excluded from our Creative Commons license.  
For more information, see <http://ocw.mit.edu/fairuse>.

# An Historic Fourier Transform

---

This is an x-ray crystallographic image of DNA, and it shows the Fourier transform of the structure of DNA.

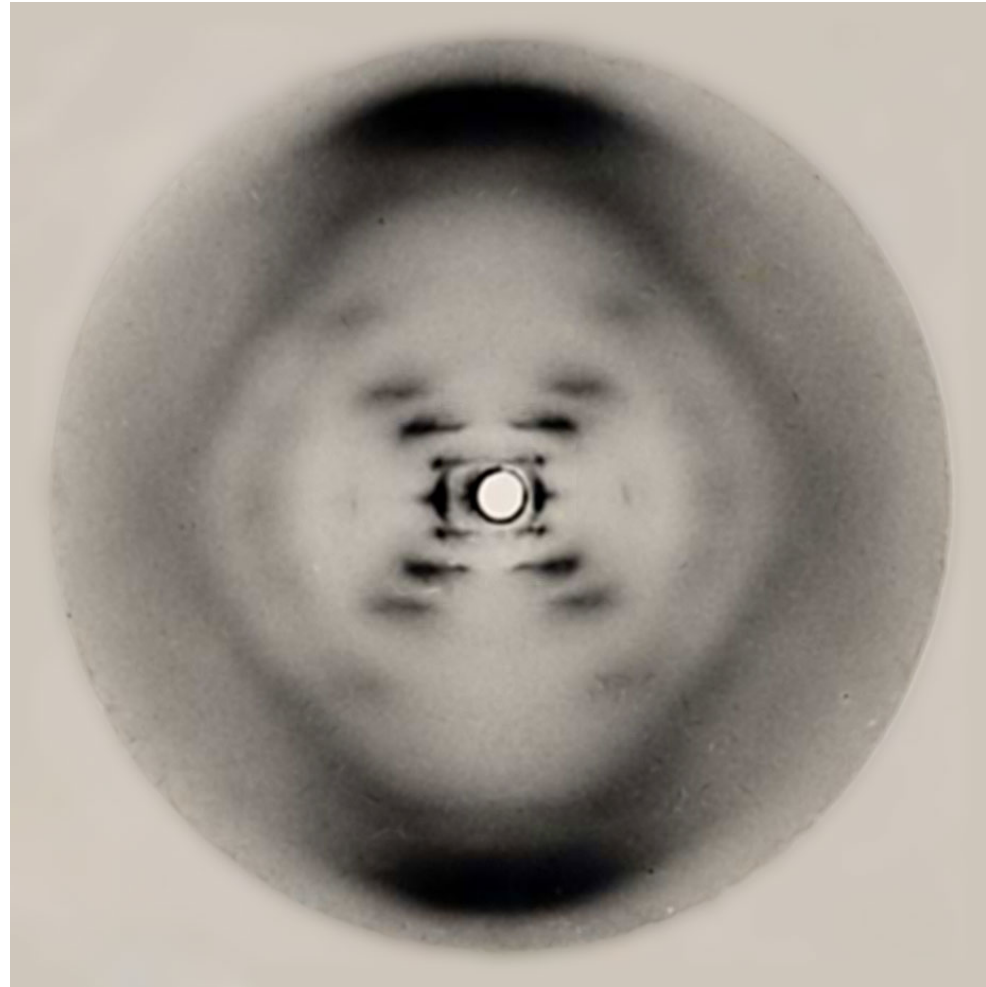
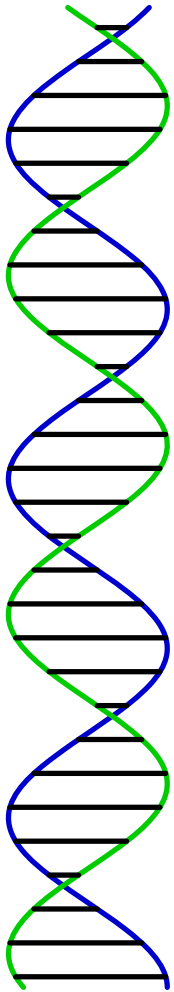

© Source unknown. All rights reserved.  
This content is excluded from our Creative Commons license.  
For more information, see <http://ocw.mit.edu/fairuse>.

# An Historic Fourier Transform

High-frequency bands indicate repeating structure of base pairs.

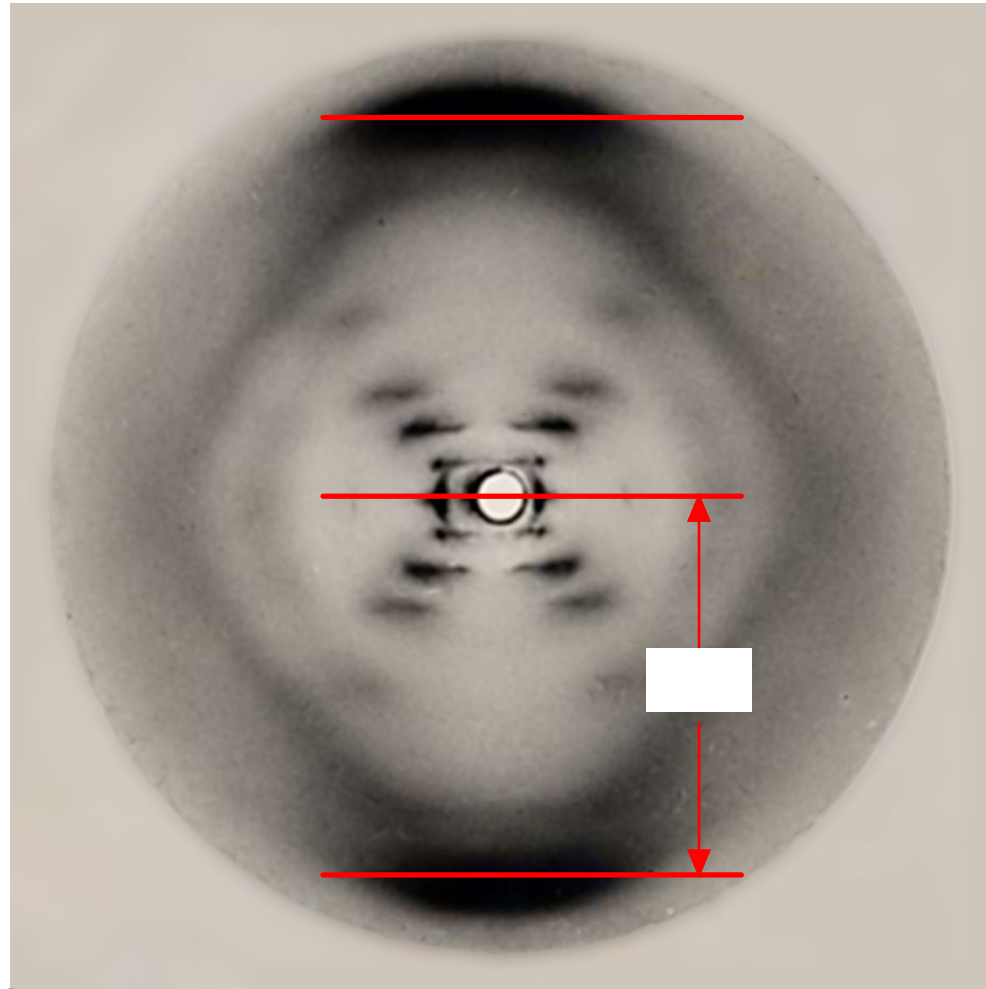
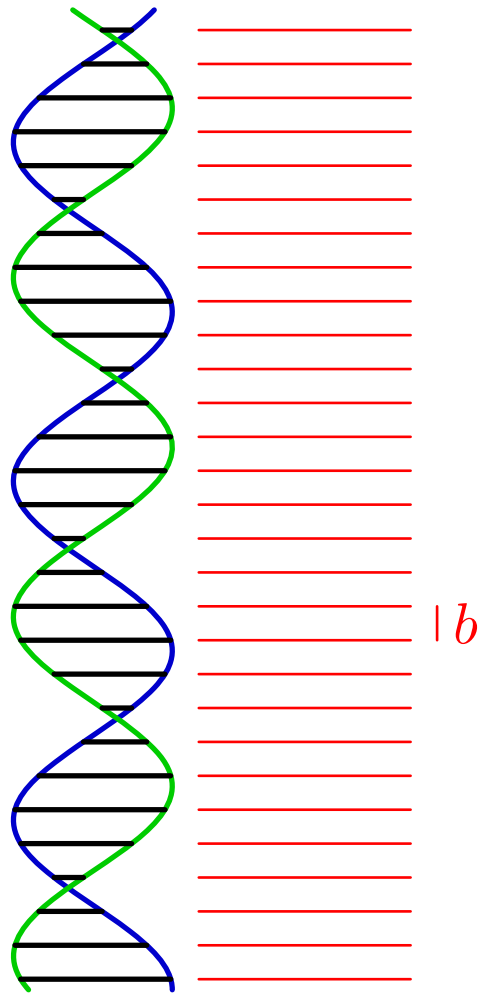

© Source unknown. All rights reserved.  
This content is excluded from our Creative Commons license.  
For more information, see <http://ocw.mit.edu/fairuse>.

# An Historic Fourier Transform

Low-frequency bands indicate a lower frequency repeating structure.

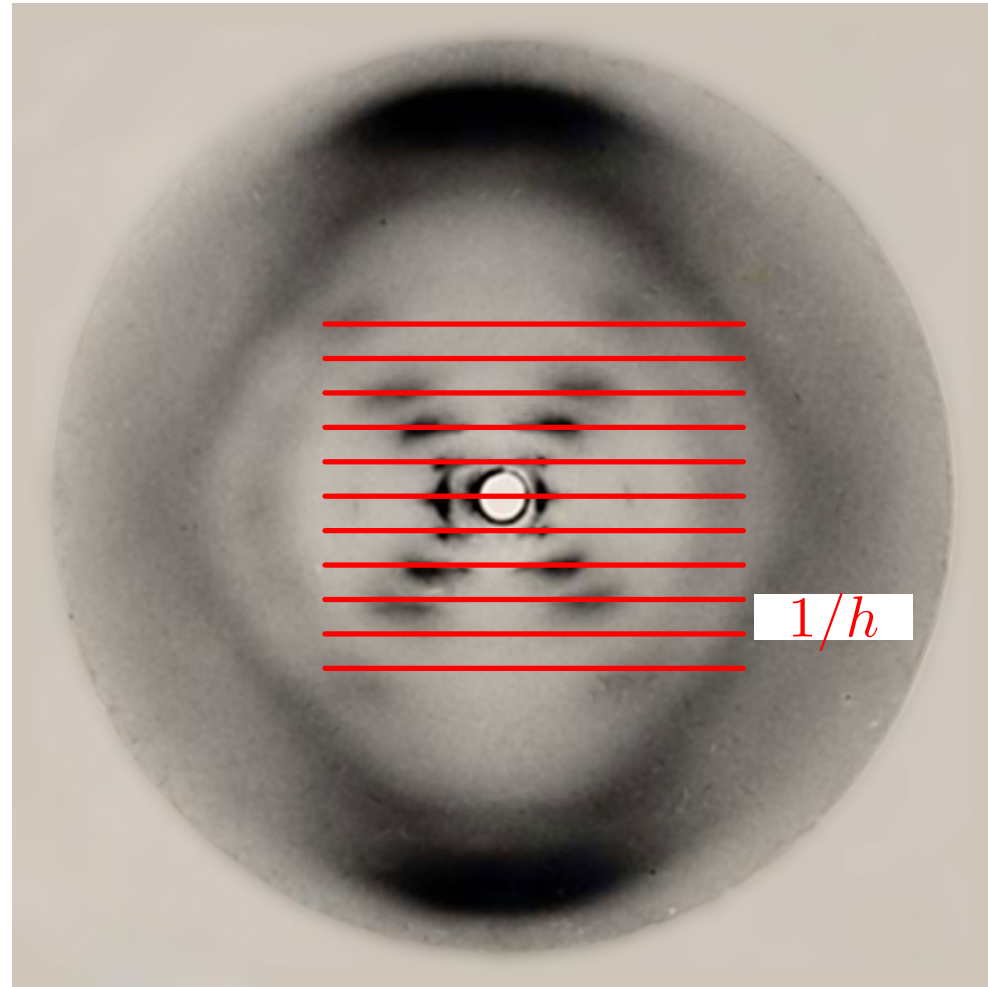
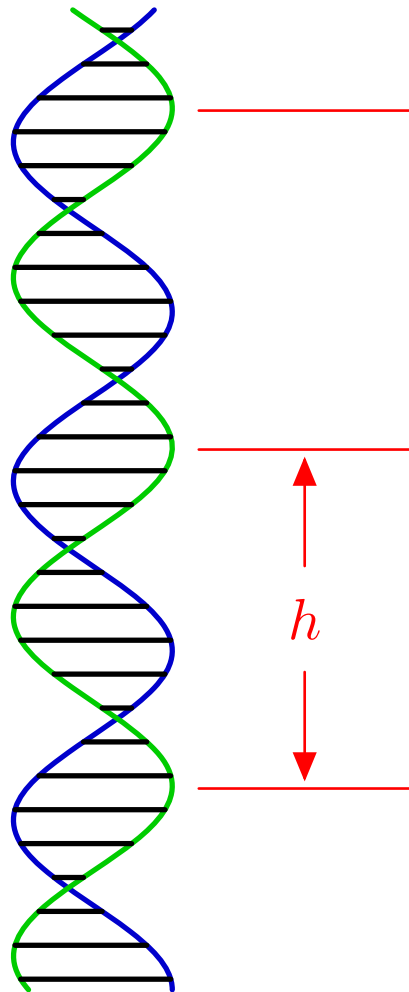

© Source unknown. All rights reserved.

This content is excluded from our Creative Commons license.

For more information, see <http://ocw.mit.edu/fairuse>.

# An Historic Fourier Transform

---

Tilt of low-frequency bands indicates tilt of low-frequency repeating structure: the double helix!

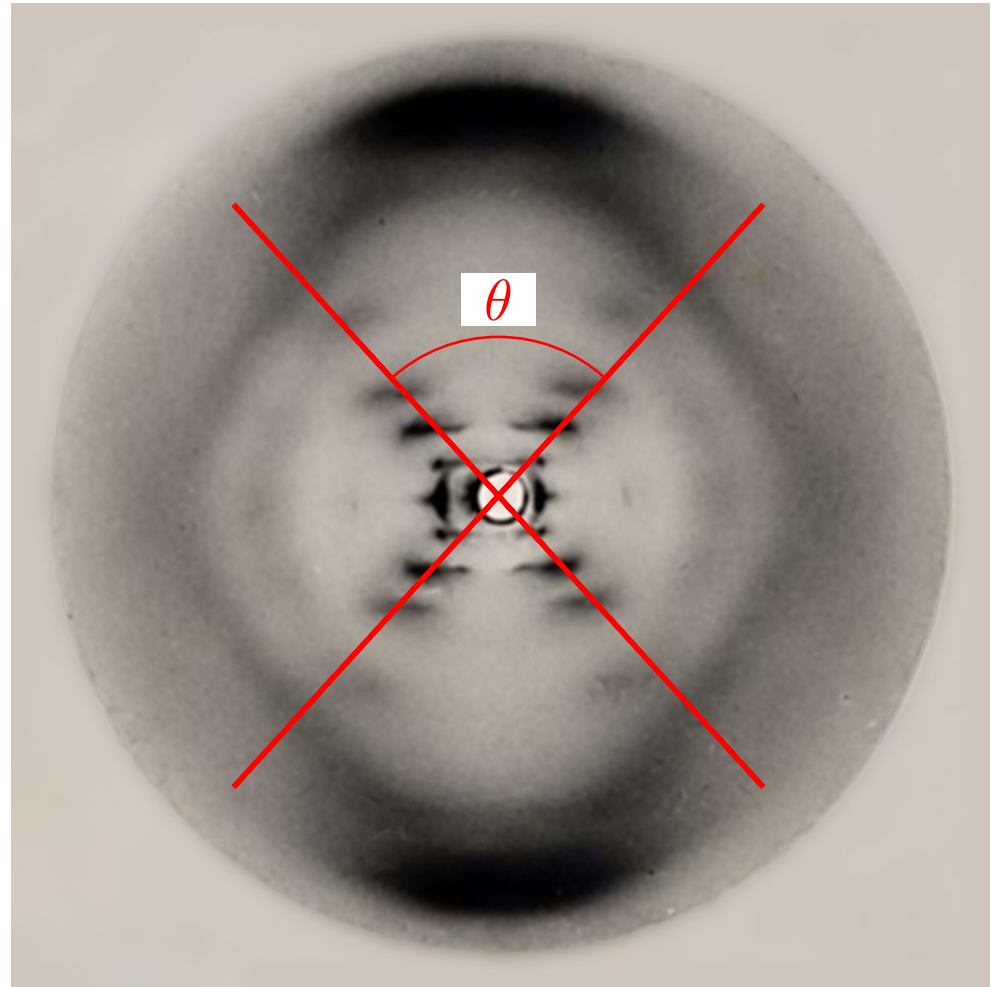
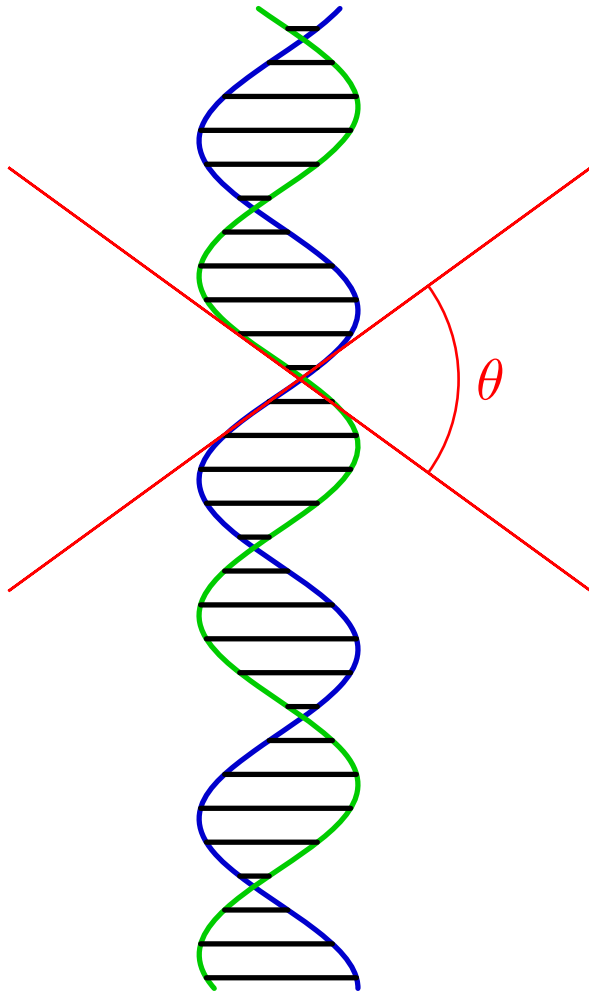

© Source unknown. All rights reserved.  
This content is excluded from our Creative Commons license.  
For more information, see <http://ocw.mit.edu/fairuse>.

# Simulation

---

Easy to calculate relation between structure and Fourier transform.

Images removed due to copyright restrictions.

Left: double helix drawing. Right: x-ray diffraction image.

# Fourier Transform Summary

---

Represent signals by their frequency content.

Key to “filtering,” and to signal-processing in general.

Important in many physical phenomenon: x-ray crystallography.



MIT OpenCourseWare  
<http://ocw.mit.edu>

6.003 Signals and Systems  
Spring 2010

For information about citing these materials or our Terms of Use, visit: <http://ocw.mit.edu/terms>.